

MESSRS. : _____

AGENT : _____

SPECIFICATION of Optical Lens

MODEL NO. : HARAC-2-LENS

 **NIPPON CERAMIC CO., LTD.**
176-17 Hirooka, Tottori-shi, 689-1193 JAPAN
TEL: +81-857-53-4666 FAX: +81-857-53-3532

Approved by	Checked by	Prepared by

MODEL NO. : HARAC-2-LENS	DRAWING NO. :	REV : A	PAGE 1 / 6	 NIPPON CERAMIC CO., LTD.
PART NO. :				

1. Scope

This specification describes a optical lens which is used for passive infrared detector.

2. Type of Lens

2.1. Type Name: Spherical shape optical lens

2.2. Model No.: HARAC-2-LENS

3. Dimensions

See Figure 1.

4. Material

High Density Polyethylene (HDPE)

5. Color

Natural

6. Optical Characteristics**6.1. Number of Segments**

20 Segments

6.2. Detection Area

See Figure 2.

7. Environmental Characteristics**7.1. Operating Temperature**

-20 °C ~ +70 °C

7.2. Storage Temperature

-25 °C ~ +75 °C

7.3. Operating humidity

95%RH or less(30 °C)

7.4. Storage humidity

95%RH or less(30 °C)

* Please avoid using the lens in direct sunshine conditions because it may cause degradation of the transmittivity.

MODEL NO. : HARAC-2-LENS	DRAWING NO. :	REV : A	PAGE 2 / 6	 NIPPON CERAMIC CO., LTD.
PART NO. :				

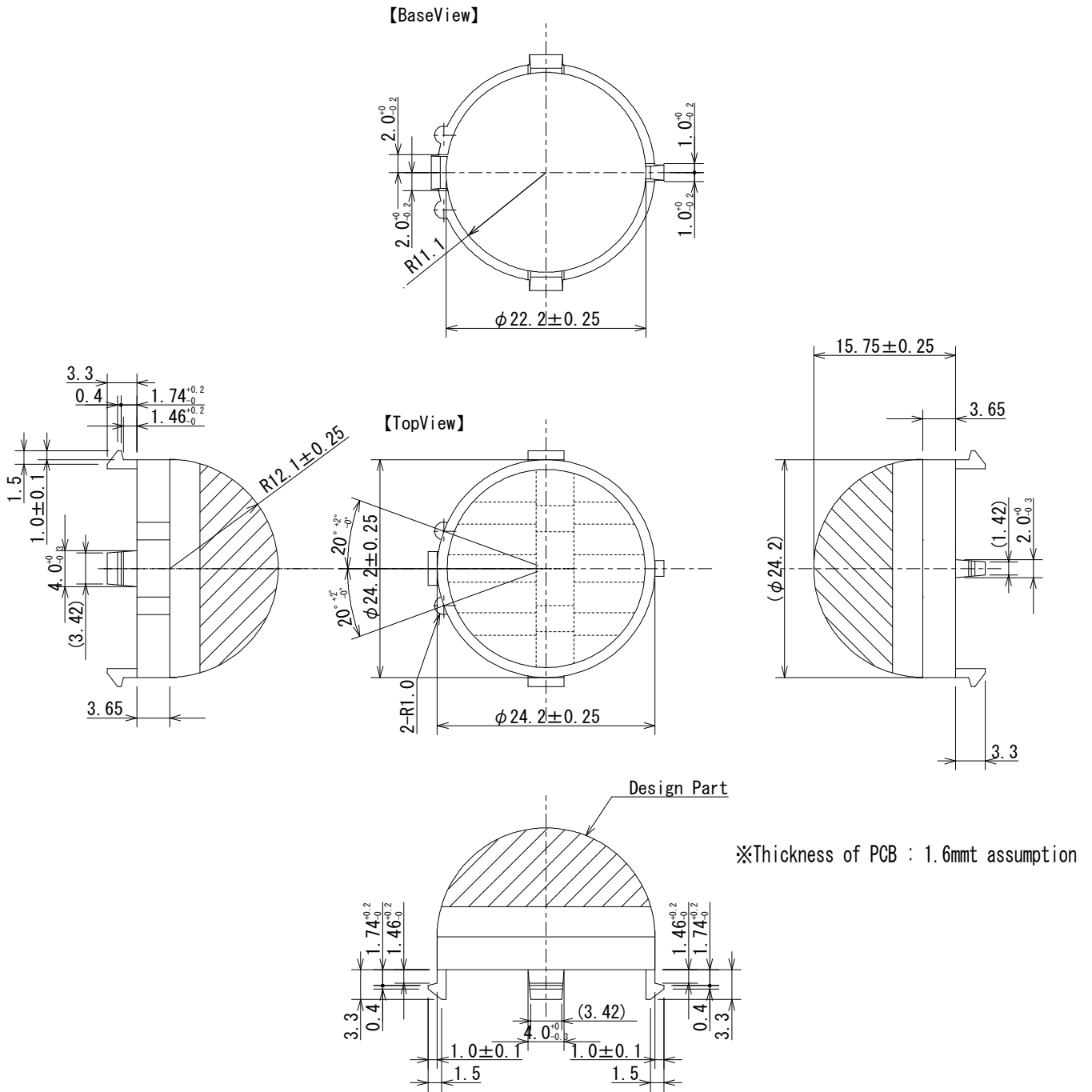

Tolerance without instruction : (+/-) 0.2
Unit [mm]

Figure 1: Dimensions

MODEL NO. : HARAC-2-LENS	DRAWING NO. :	REV : A	PAGE 3 / 6	
PART NO. :				

Dual Element type(Element size : 2.3*1.0-Gap1.0)

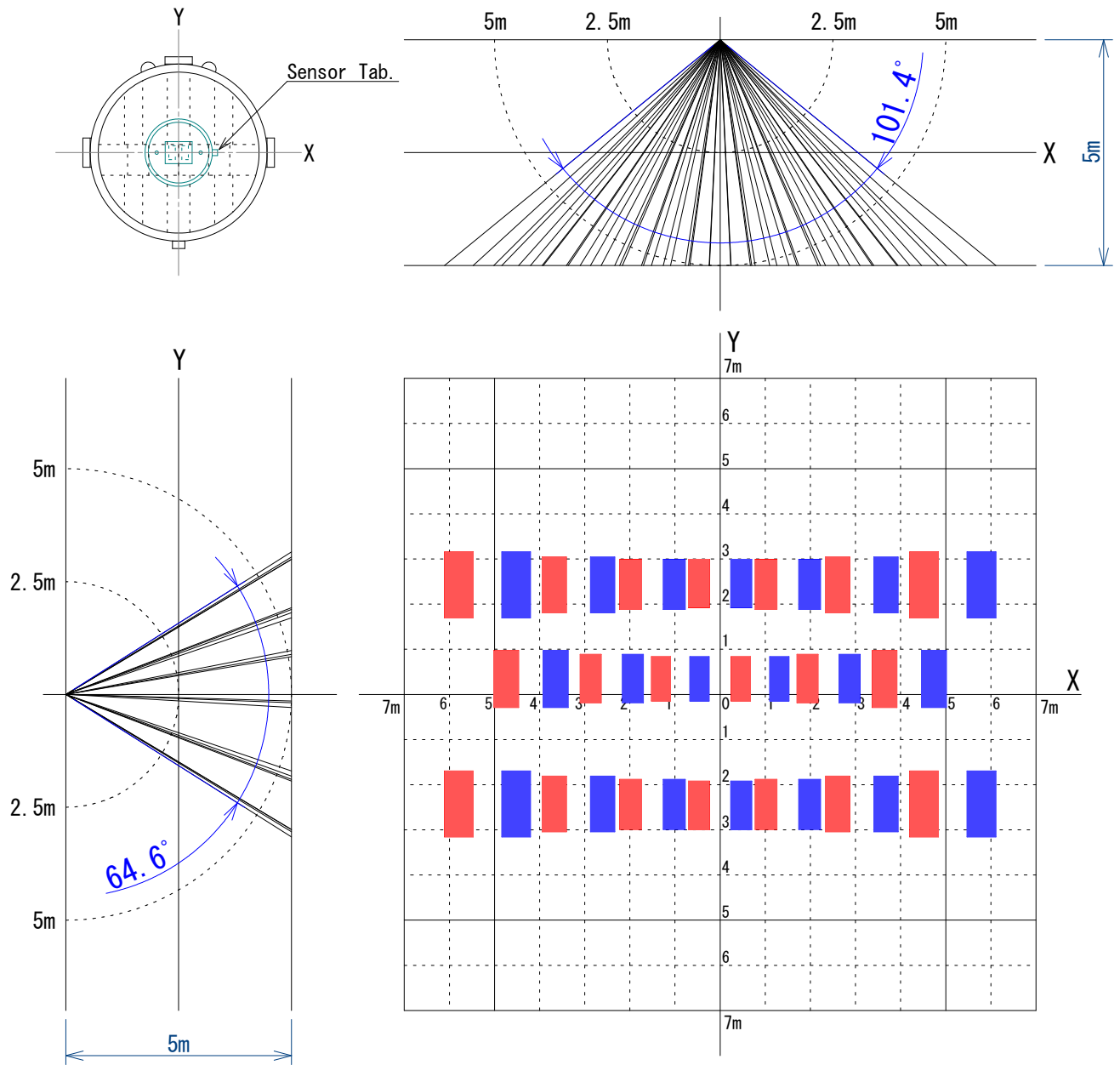

Zone : 40

Distance : 5m
(Traverse Plane)

Unit [m]

Figure 2A: Detection Area (with Dual Element PIR)

MODEL NO. : HARAC-2-LENS	DRAWING NO. :	REV : A	PAGE 4 / 6	
PART NO. :				

Dual Element type(Element size : 2.3*1.0-Gap1.0)

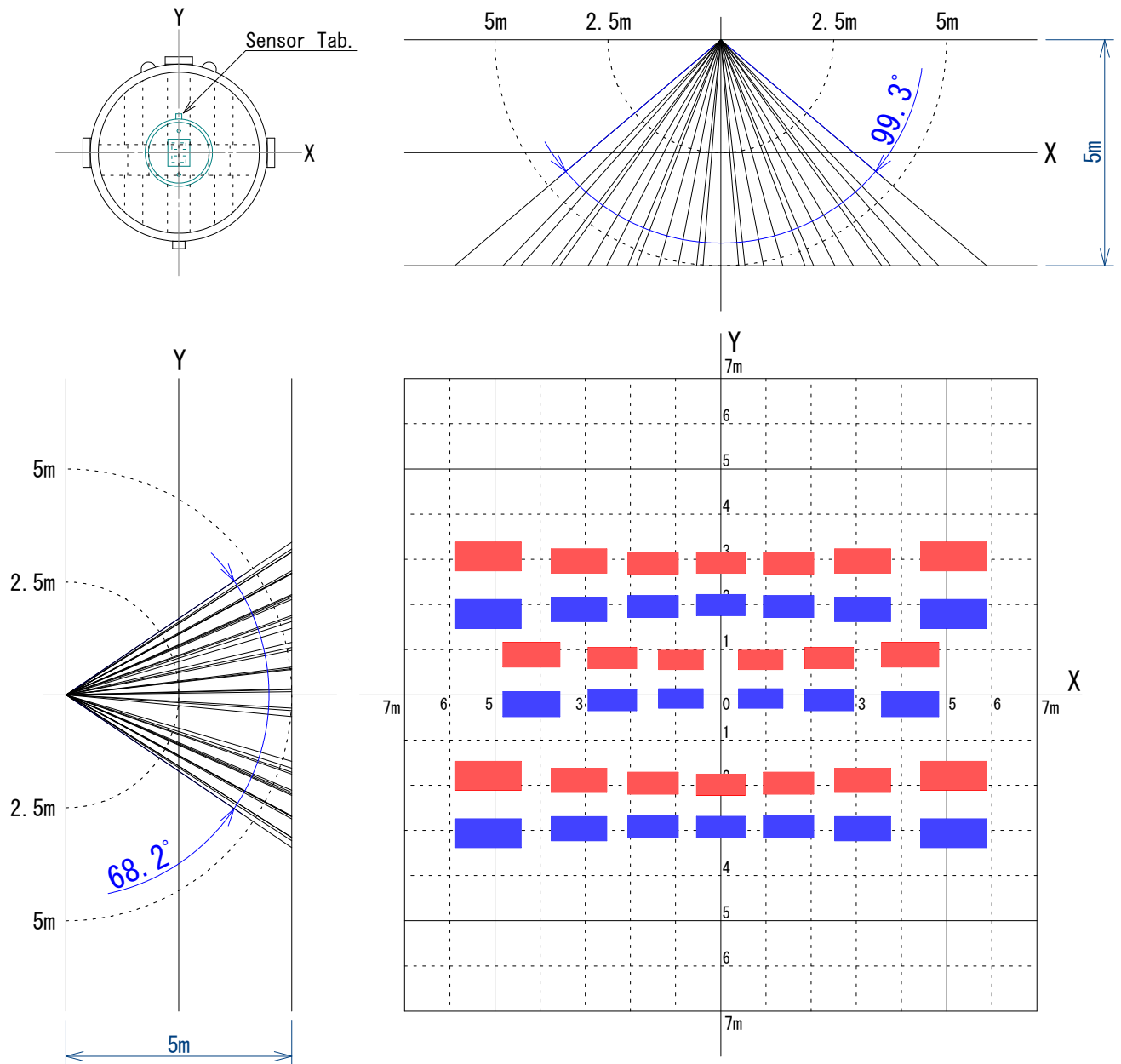

Zone : 40

Distance : 5m
(Traverse Plane)

Unit [m]

Figure 2B: Detection Area (with Dual Element PIR)

MODEL NO. : HARAC-2-LENS	DRAWING NO. :	REV : A	PAGE 5 / 6	
PART NO. :				

Packing Specification

The products are put into a plastic bag, and the plastic bags are packed in an inner box.

1. Standard Package Quantity : 2,000pcs.
2. Product arrangement : 2,000 pcs. / plastic bag
3. Packing : 1 bag × 2,000 pcs. / 2,000 pcs.

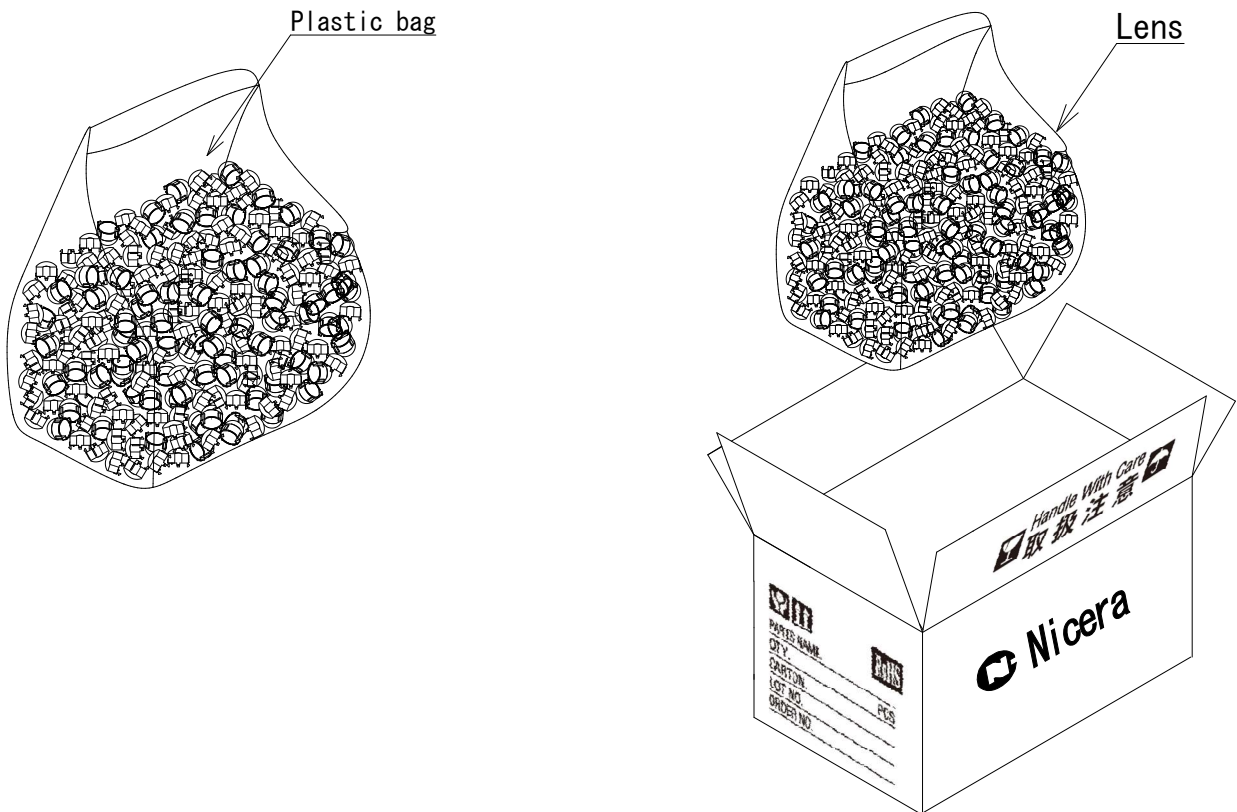

4. Packing in a box

The outer box is sealed with stick tape.

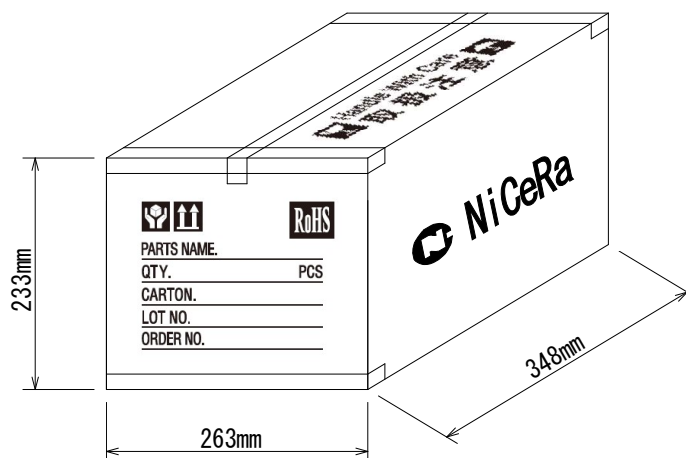

MODEL NO. : HARAC-2-LENS	DRAWING NO. :	REV : A	PAGE 6 / 6	
PART NO. :				