

SPECIFICATION

Product Name: Electrochemical CO Sensor

Item No.: ECO-5011

Version: V0.2

Date: May 25, 2022

Revision

No.	Version	Content	Date
1	V0.1	Preliminary version	2021.08.27
2	V0.2	<ol style="list-style-type: none">1. Long-term output drift improves from 5% of reading/year to 3% of reading/year.2. Add anti-interference characteristic data.	2022.05.25

Electrochemical CO Sensor

ECO-5011

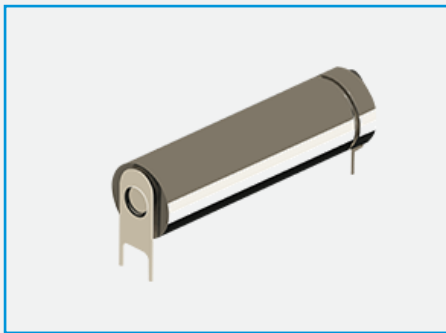

Applications

- Residential and commercial CO detector
- Industrial CO monitoring
- Indoor and underground parking lot ventilation control
- Fire alarm
- Automotive safety alarm
- Smart home CO monitoring

Description

ECO-5011 is a battery operable electrochemical sensor. Compared with other existing electrochemical sensor, it uses a more environmentally friendly electrolyte, and the packaging technology won't cause any leakage risk. Moreover, ECO-5011 has features of detecting CO concentration up to 10,000ppm, wide working temperature range, low cross gas interference, and longer lifetime, etc.

Features

- Battery operable
- High selectivity to CO and good repeatability
- High linear output characteristics for CO measurement
- Long lifetime (8+ years), good long-term stability
- Low sensitivity to ethanol and acetic acid, resistance to organic silicon poisoning
- Meet UL2034, EN50291 and ROHS requirements

Working Principle

ECO-5011 is a fuel cell type gas sensor.

Carbon monoxide and oxygen undergo a corresponding redox reaction on the working and counter electrode, then release charges to form currents.

The generated current is proportional to the CO concentration and follows Faraday's law.

The CO concentration can be determined by measuring the current.

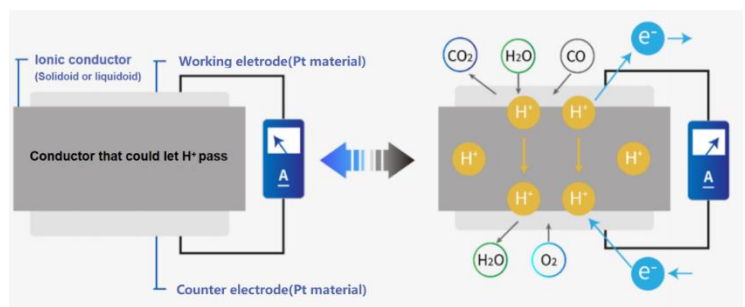

Specifications

ECO-5011 Gas Sensor Specification	
Target gas	Carbon monoxide (CO)
Working principle	Electrochemical technology
Measurement range	0~10000ppm
Sensitivity	1.5-3nA/ppm
Repeatability	±2% of reading
Resolution	0.5ppm
Response time (T90)	<60s
Long-term output drift	<3% of reading/ year
Working temperature	-20 ~ +60°C
Storage temperature	-20 ~ +60°C
Relative humidity	5~99%RH (non-condensing)
Working pressure range	100 kPa ± 10%
Bias voltage	No requirements
Recommended load resistance	1000 Ω
Lifetime	8+ years
Weight	12g

Product Dimensions

1. Dimensions (Unit: mm)

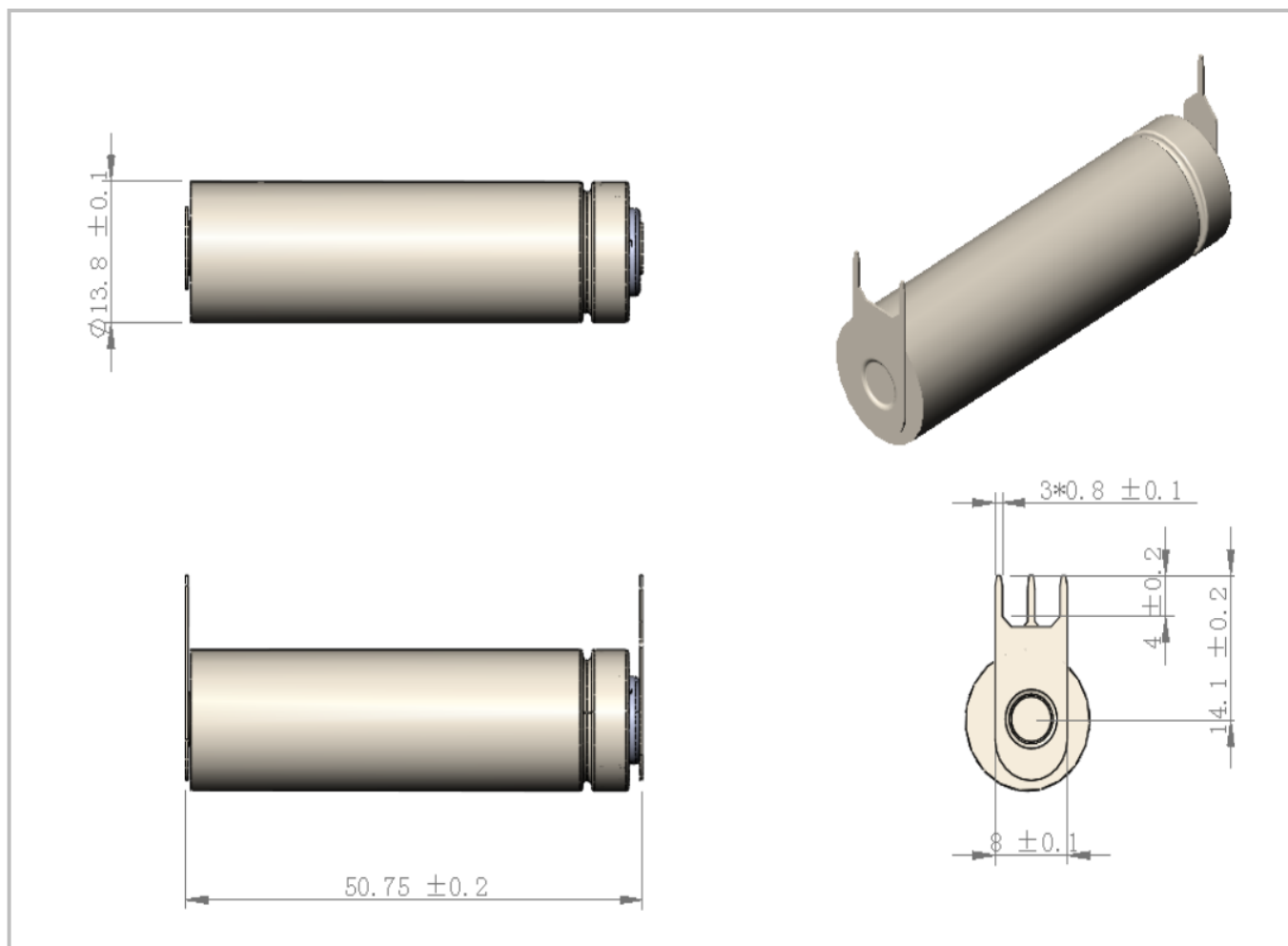

Sensitivity Characteristic Curve

ECO-5011 measured a typical sensitivity characteristic curve under standard test conditions ($20\pm 2^{\circ}\text{C}$, 50%RH). The vertical coordinate represents sensor's current output (μA) in CO gas, the horizontal coordinate represents CO gas concentration (ppm). It shows a high linearity within $\pm 5\%$ in the range of 0-10000ppm, figure as below:

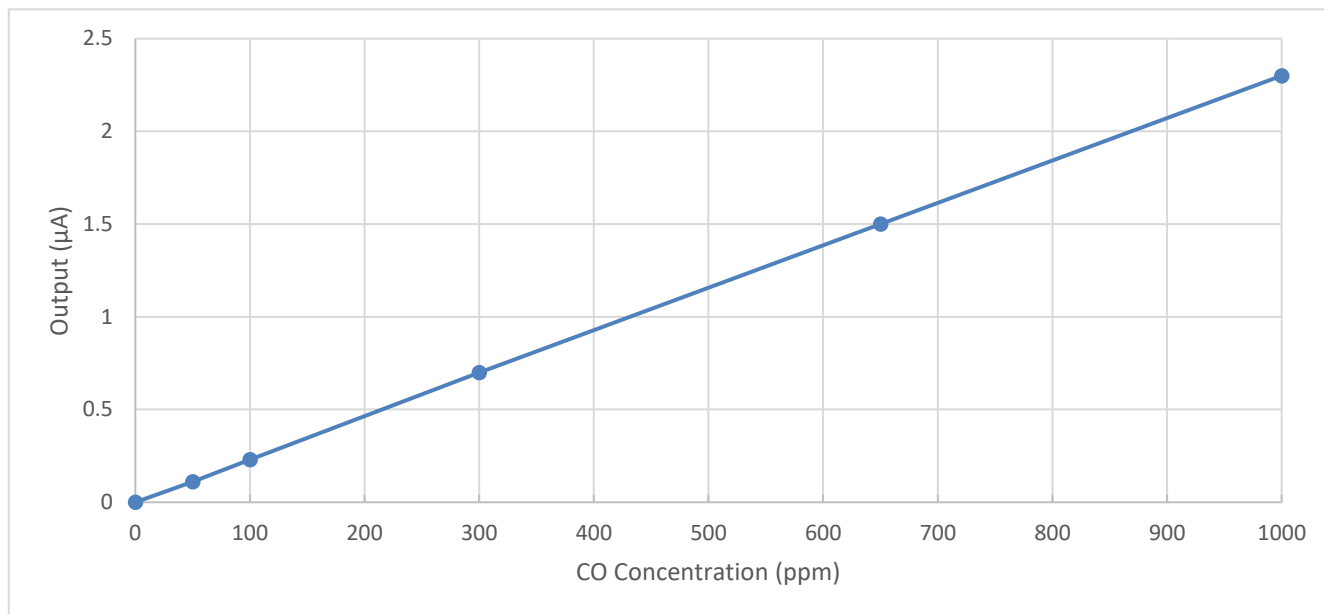

Temperature Influence Curve

Under conditions of 50%RH and constant temperature, ECO-5011 performs a typical curve of current output with temperature. The vertical coordinate represents sensor's output ratio (based on current signal value tested at 20°C , 50%RH), the horizontal coordinate represents sensor's test ambient temperature ($^{\circ}\text{C}$), figure as below:

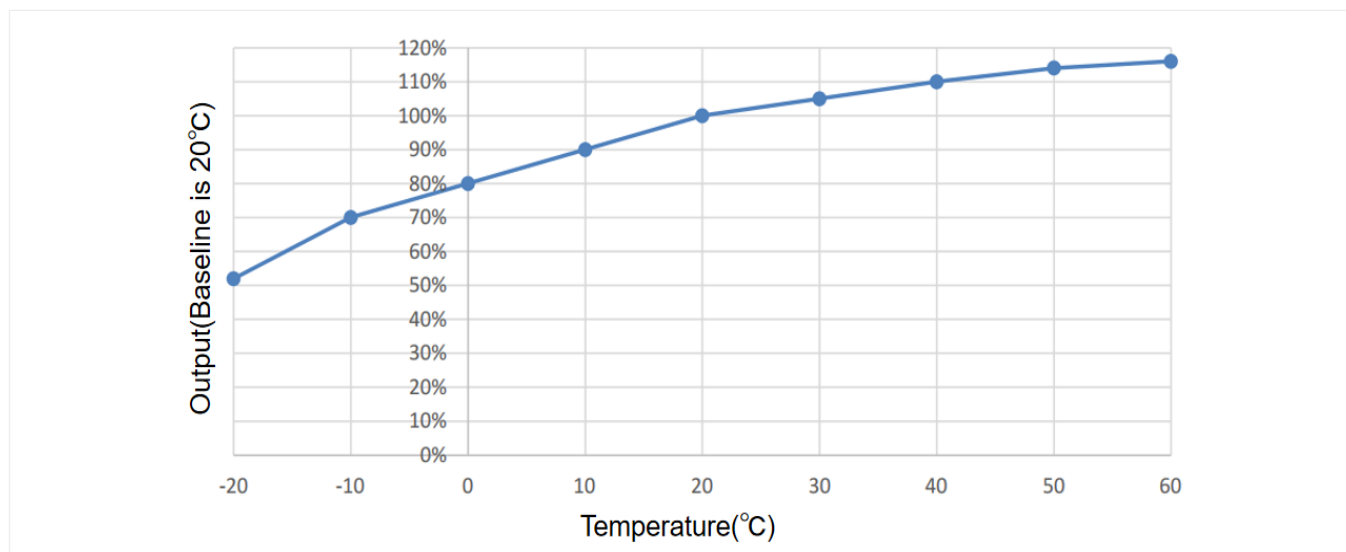

Anti-interference Characteristic

Cross Gas	Concentration of Cross Gas (ppm)	Equivalent CO Concentration (ppm)
Hydrogen (H ₂)	1000	350
Acetylene (C ₂ H ₂)	200	300
Ethylene (C ₂ H ₄)	1000	100
Methane (CH ₄)	1000	10
Butane (C ₄ H ₁₀)	1000	0
Carbon Dioxide (CO ₂)	1000	0
Nitrogen Dioxide (NO ₂)	1000	30
Sulfur Dioxide (SO ₂)	200	8
Formaldehyde (HCHO)	200	0
Ammonia (NH ₃)	200	0
Propanol (C ₃ H ₈ O)	1000	0
Acetic Acid (CH ₃ COOH)	2000	0
Ethanol (CH ₃ CH ₂ OH)	2000	0
Hexamethyldisiloxane (C ₆ H ₁₈ OSi ₂)	1000	0
Acetone (CH ₃ COCH ₃)	1000	0

Important Note: The use condition of ECO-5011 sensor will vary depending on the specific application of different customers. We recommend consulting us at info@gassensor.com.cn before use, especially when going to detect gas other than carbon monoxide. Cubic won't be responsible for any operation beyond ECO-5011 product specifications.

Precautions

1. The power-on aging time should not be less than 30 minutes.
2. If the water in ECO-5011 sensor container gets quickly frozen (usually due to mishandling), sensor characteristics may get changed irreversibly. To avoid such a risk, please keep the cap (working electrode) facing upwards when storing ECO-5011.
3. If in need of a wider working temperature (current range is $-20 \sim +60^{\circ}\text{C}$), please contact Cubic for more supports.

After-Sales Services and Consultancy

Cubic Sensor and Instrument Co.,Ltd.

Tel: +86 (0)27 81628827 Fax: +86 (0)27 81628821

Add: Fenghuang No.3 Road, Fenghuang Industrial Park, Eastlake Hi-tech Development Zone,
Wuhan 430205, China

Website: www.gassensor.com.cn

Email: info@gassensor.com.cn