

SPECIFICATION

Product Name: Single Beam NDIR CO₂ Sensor Module

Item No.: CM1106S-W

Version: V0.1

Date: June 18, 2020

Writer	Audit	Approved
Mei Yang		

Revision

No.	Version	Content	Reviser	Date
1	V0.1	First Version	Li Shaoyong	2020.06.18

Single Beam NDIR CO₂ Sensor Module

CM1106S-W



Applications

- HVAC industry
- IAQ monitor
- Air purifier
- Automotive
- IoT devices
- Plant growth

Description

CM1106S-W is a single beam NDIR CO₂ sensor module, based on non-dispersive infrared (NDIR) technology, which can detect CO₂ concentration of indoor air. With high accuracy, high stability, small size, it is widely used for ventilation system, air purifier, air conditioner, HVAC transmitter, IAQ monitor, etc.

Features

- NDIR technology with independent intellectual property
- High accuracy, long term stability, long life (>10years)
- Temperature calibration within whole measurement range
- Auto-calibration, no need of maintenance
- Signal output UART/I²C
- Small size and compact structure, easy to install

Working Principle

The main components of an NDIR CO₂ sensor are an infrared source, a sample chamber, a filter and an infrared detector. The infrared light is directed by the infrared source passing through the gas chamber towards the detector.

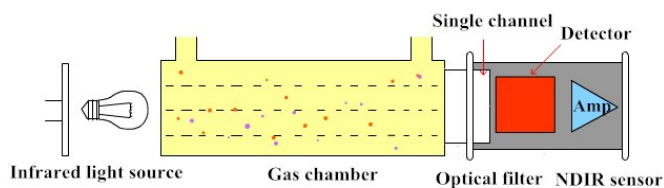

CO₂ molecules inside the gas chamber will only absorb a specific wavelength of the light. The filter allows only the specific wavelength corresponded to pass through it. The detector measures the intensity of infrared light that is related to the intensity of CO₂ and can be described through the Lambert-Beer's Law. The change in sensor signal reflects the change in gas concentration.

Specifications

Single Beam NDIR CO ₂ Sensor Specification	
Target gas	Carbon dioxide (CO ₂)
Operating principle	Non-dispersive infrared (NDIR)
Measurement range	0-5000ppm
Working temperature	-10°C ~ 50°C
Working humidity	0-95%RH (non-condensing)
Storage temperature	-30°C ~ 70°C
Storage humidity	0-95%RH (non-condensing)
Accuracy	± (50ppm+3% of reading) @0°C~50°C, 50±10%RH (Note 1 and 2)
Sampling frequency	1s
Time to first reading	30s
Power supply	DC4.5V-5.5V
Ripple wave	<50mV
Working current	≤20mA
Dimensions	39.3x19.7x9.1mm
Weight	6g
Signal output	UART_TTL I ² C (reserved)
Alarm output (Reserved)	According to customer's actual usage environment and requirements
Life span	≥10 years

Note 1: In normal IAQ applications, accuracy is defined after minimum three (3) ABC periods of continuous operation with ABC on. Some industrial applications do require maintenance. Contact Cubic for further information.

Note 2: Specification is referenced to certified calibration mixtures. Uncertainty of calibration gas mixtures (±2% currently) is to be added to the specified accuracy for absolute measurement.

Dimensions and Connector

1. Dimensions (Unit mm, tolerance ± 0.2 mm)

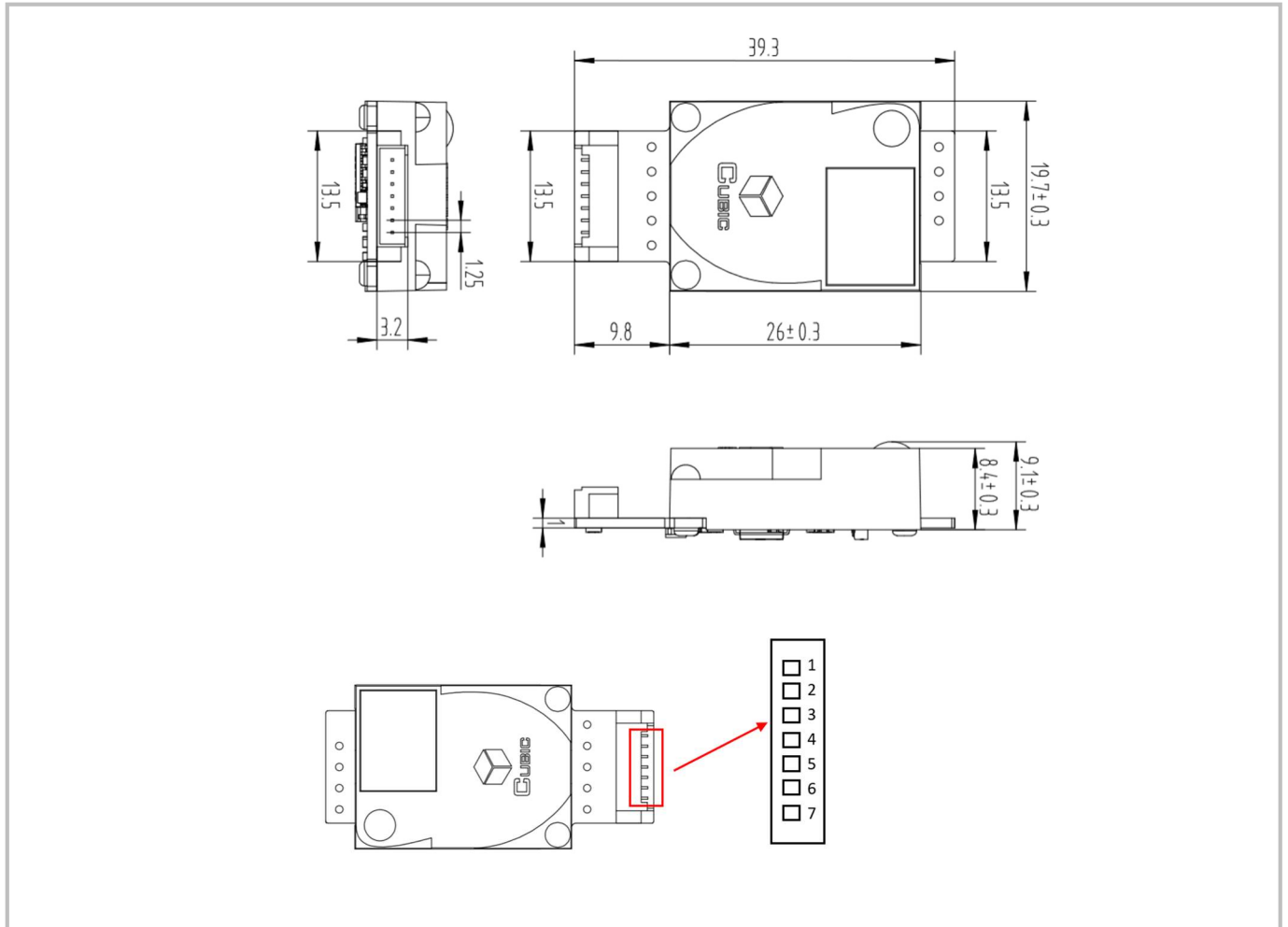

2. I/O Connector Pinout

Pin	Name	Description	Pin	Name	Description
1	NC	Not Connected	5	RX/SDA	UART-RX (Receiving)/I ² C data, compatible with 3.3V and 5V communication
2	NC	Not Connected	6	TX/SCL	UART-TX (Sending)/I ² C clock, Compatible with 3.3V and 5V communication
3	GND	Power supply input (GND)	7	R/T	Output mode exchange: High level or floating is UART communication mode, low level is I ² C communication mode
4	VCC	Power supply input (4.5V-5.5V)			

Typical Application Circuit

Application scene: UART_TTL serial port output

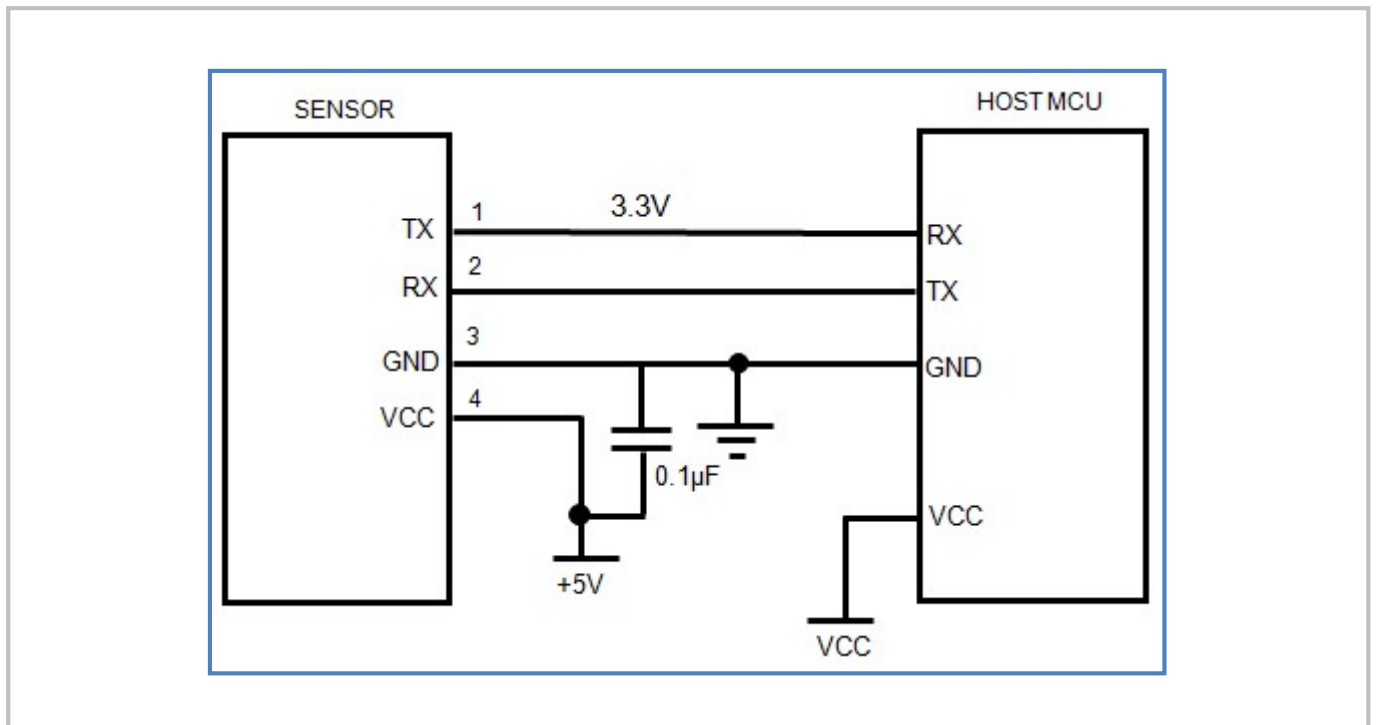

Application scene: 3.3V- 5V Level Shift

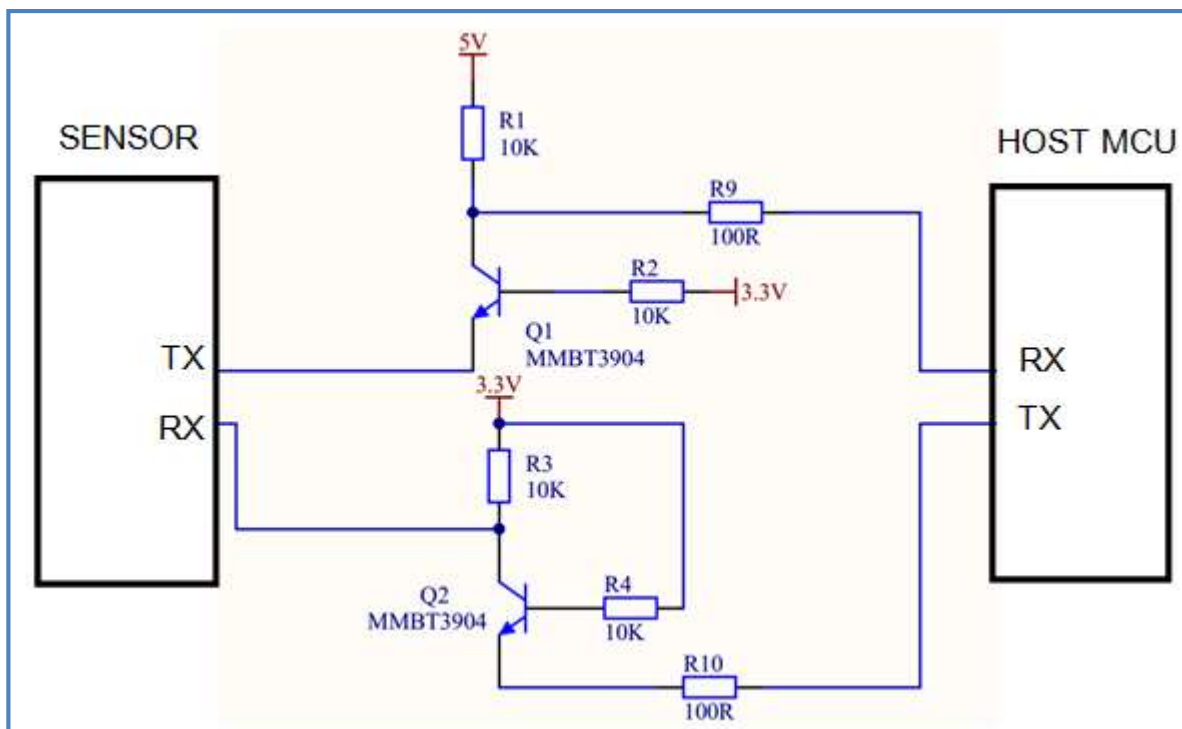

Description of Calibration

Auto Calibration:

Rough installing and influence of transportation might result in reducing of sensor measuring accuracy and baseline drift, sensor will correct the drift by the built-in self-correcting logic, and the auto baseline correction period is 24 hours+7 days. Powering on the sensor for 24 hours continuously, it will record the lowest CO2 concentration measurement value during the 24 hours, which will be regarded as baseline (400ppm) when sensor do auto calibration after the 24 hours working, and then the sensor will enter regular 7 days correction cycle, auto calibration will be implemented every 7 days. In order to ensure correct auto calibration, please make sure working environment of the sensor can reach to outdoor fresh air level (400ppm) during the 24 hours and regular 7 days auto baseline correction cycle.

Note:

1. If auto calibration environment cannot be ensured, then regular manual calibration is recommended, please refer to the communication protocol 4.3, implement calibration and set the CO2 concentration as 400ppm under fresh air environment.
2. Please contact with Cubic for more detailed auto calibration strategy.

UART Communication Protocol

1. General Statement

- 1). The data in this protocol is all hexadecimal data. Example: "46" for decimal [70].
- 2). Baud rate: 9600, Data Bits: 8, Stop Bits: 1, Parity: No, Flow control: No.
- 3). [x x] is for single-byte data (unsigned, 0-255); for double data, high byte is in front of low byte.

2. Format of Serial Communication Protocol

Sending format of test software:

Start Symbol	Length	Command	Data1	...	Data n.	Check Sum
HEAD	LEN	CMD	DATA1	...	DATAn	CS
11H	XXH	XXH	XXH	...	XXH	XXH

Detail description on protocol format:

Protocol Format	Description
Start Symbol	Sending by test software is fixed as [11H], module response is fixed as [16H]
Length	Length of frame bytes= data length +1 (including CMD+DATA)
Command	Command
Data	Data of writing or reading, length is not fixed
Check Sum	Cumulative sum of data = 256-(HEAD+LEN+CMD+DATA)%256

3. Command Table of Serial Protocol

Item No.	Function Name	Command
1	Read measured result of CO ₂	0x01
2	Open/ Close ABC and set ABC parameter	0x10
3	Calibrate concentration value of CO ₂	0x03
4	Read the serial number of the sensor	0x1F
5	Read software version	0x1E

4. Detail Description of UART Protocol

4.1 Read Measured Result of CO₂

Send: 11 01 01 ED

Response: 16 05 01 DF1- DF4 [CS]

Function: Read measured result of CO₂ (Unit: ppm)

Note:

CO₂ measured result = DF1*256+DF2

DF3 DF4 is reserved

Example:

Response: 16 05 01 02 58 00 00 8A

Explanation:

Hex is converted to decimal: 02 is 02; 58 is 88 , so CO₂ concentration =02*256+88 = 600ppm

4.2 Open/Close ABC and Set ABC Parameter

Send: 11 07 10 DF1 DF2 DF3 DF4 DF5 DF6 CS

Response: 16 01 10 D9

Explanation:

DF1: reserved, default 100 (0x64)

DF2: open/close auto calibration (0: open; 2: close)

DF3: calibration cycle (1-30 days optional, default is 7 days)

DF4: High base value (2 bytes)

DF5: Low base value (2 bytes)

DF6: reserved, default is 100 (0x64)

Note: The auto calibration function is open with 7 days calibration cycle by default.

The default value of DF4 and DF5 is 400, that is DF4: 01; DF5:90

4.2.1 Close ABC

In our sensor, the ABC function is default open status. If you want to close it, you should set the DF2=2.

Example:

Send: 11 07 10 64 02 07 01 90 64 76

Response: 16 01 10 D9

4.2.2 Open ABC and Set Calibration Cycle

When ABC function is closed and you want to re-open ABC function, you should set the DF2=0.

Example:

you could send below command to open ABC function and set the calibration cycle 7 days.

Send: 11 07 10 64 00 07 01 90 64 78

Response: 16 01 10 D9

4.2.3 Change the Calibration Cycle

The calibration cycle is 7 days by default. For example, if you want to change the calibration cycle to 10 days, you should set the DF3=10.

Example:

Send: 11 07 10 64 00 0A 01 90 64 75

Response: 16 01 10 D9

4.3 Calibration of CO₂ Concentration

Send: 11 03 03 DF1 DF2 CS

Response: 16 01 03 E6

Function: Calibration of CO₂ concentration

Note:

1. Calibration target value = DF1*256+DF2 Unit: PPM, range (400-1500ppm)
2. Before calibration, please make sure CO₂ concentration in current ambient is calibration target value. Keeping this CO₂ concentration for two 2 minutes, then began calibration.

Example:

When you need to calibrate CO₂ concentration of the sensor to 600ppm, send command:

Send: 11 03 03 02 58 8F

Hex is converted to decimal: 02 is 02; 58 is 88, so CO₂ concentration =02*256+88 = 600ppm

4.4 Read the Serial Number of the Sensor

Send: 11 01 1F CF

Response: 16 0B 1F (SN1) (SN2) (SN3) (SN4) (SN5) [CS]

Function: Read the serial number of the sensor

Note: Read the serial number of the sensor. SNn: 0~9999, 5 integer form 20-digit number

4.5 Read Software Version

Send: 11 01 1E D0

Response: 16 0C 1E DF1-DF11 CS

Function: Read software version

Note: DF1-DF10:stand for ASCII code of software version, DF11 is reserved

Example:

When the sensor version is CM V0.0.20, response data as follows:

Hexadecimal converted to ASCII code:

Note: when 20 converted to ASCII code, it equals to blank space.

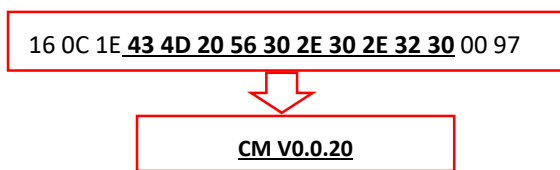

Packing Information

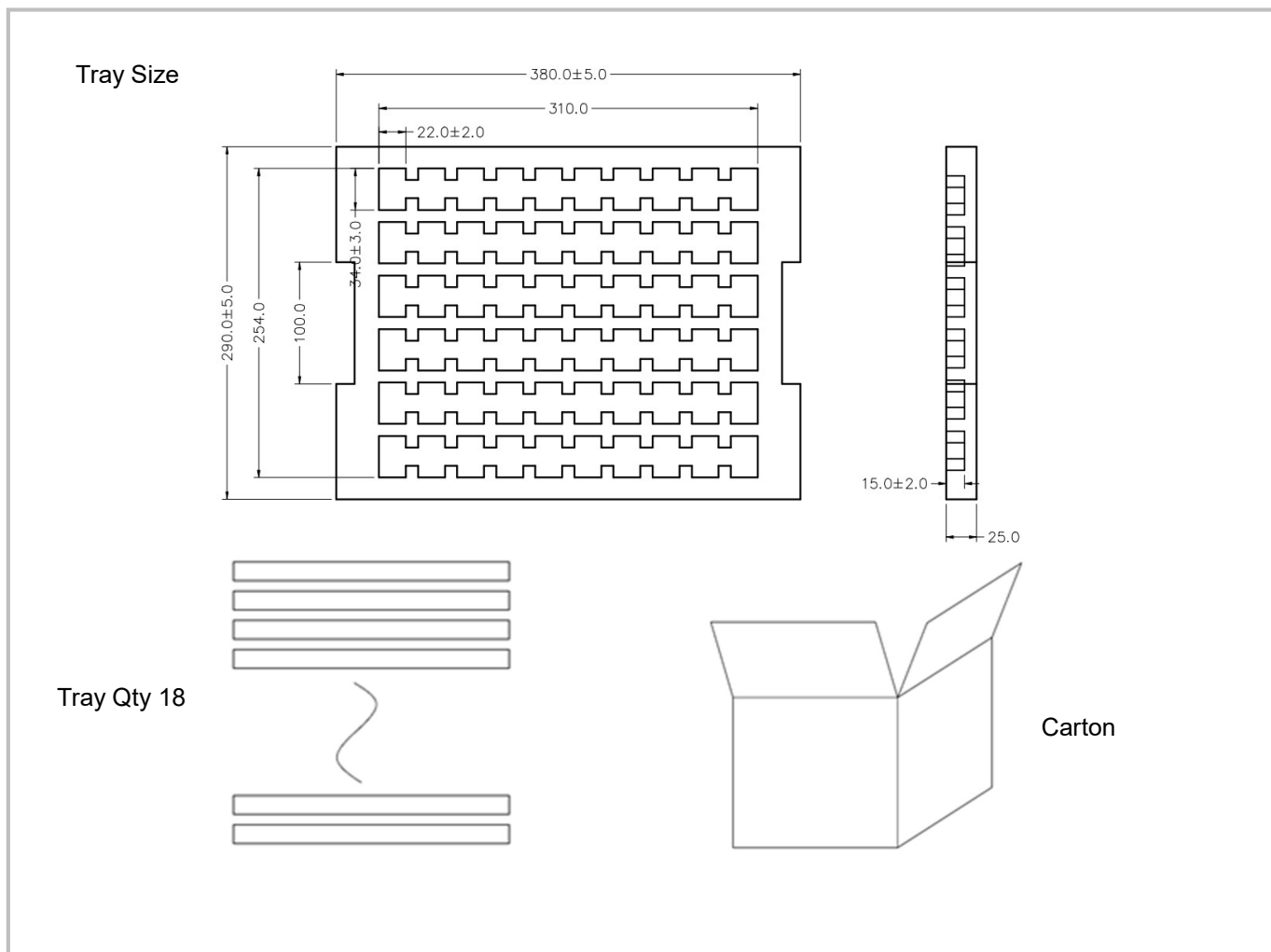

Sensor per Tray	Tray Qty	Sensor per	Carton Dimensions	Packing Material
60 pcs	18 layers	1080 pcs	395*310*480 mm	Red anti-static EPE

After-Sales Services and Consultancy

Cubic Sensor and Instrument Co.,Ltd.

Tel: +86 (0)27 81628827 Fax: +86 (0)27 81628821

Add: Fenghuang No.3 Road, Fenghuang Industrial Park, Eastlake Hi-tech Development Zone, Wuhan 430205, China

E-mail: info@gassensor.com.cn