

Series BNO – twinaxial miniature connectors

Description

HUBER+SUHNER BNO twin connectors are two pin bayonet coupled (same bayonet locking mechanism as BNC) connectors for use with balanced twin-conductor cables with 75 Ω to 130 Ω impedance. They have polarised contacts and are not intermateable with BNC.

The HUBER+SUHNER BNO twin connectors are suitable for applications up to 200 MHz (i.e. computer networks and process control).

Content

Description	337
Interface dimensions in mm/inches	337
Technical data	338
Cable connectors	339
Receptacles with solder end	341

Interface dimensions (mm/inches)

Plug (male)

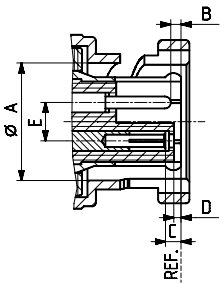

Jack (female)

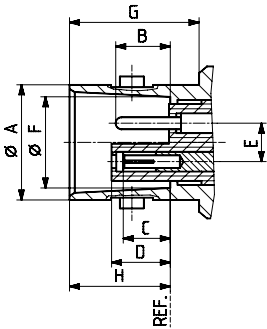

	Plug		Jack	
	min.	max.	min.	max.
A	9.78/0.385	9.91/0.390	9.60/0.378	9.70/0.382
B	0.89/0.035	1.65/0.065	4.34/0.171	5.08/0.200
C	0.81/0.032	1.80/0.071	3.96/0.156	5.08/0.200
D	0.71/0.028	1.07/0.042	4.78/0.188	5.23/0.206
E	3.14/0.124	3.26/0.128	3.14/0.124	3.26/0.128
F	-	-	8.10/0.319	8.15/0.321
G	-	-	10.52/0.414	-
H	-	-	8.36/0.329	8.46/0.333

Interface dimensions conformable to the standards:

International: IEC 60169-22

Series BNO – technical data

Electrical data	Requirements
Impedance	not defined
Frequency range (for connector interface)	DC to 200 MHz
Dielectric withstanding voltage (at sea level)	1.5 kV rms, 50 Hz between any two contacts
Insulation resistance	$\geq 10^4 \text{ M}\Omega$
Contact resistance • Centre contact • Outer contact	$\leq 2 \text{ m}\Omega$ $\leq 2 \text{ m}\Omega$

Mechanical data	Requirements
Coupling nut torque	7 to 28 Ncm/0.6 to 2.5 in. lbs
Coupling nut retention force	$\geq 450 \text{ N}/101.2 \text{ lbs}$
Cable retention force ¹⁾	see pages 32 - 37
Durability (matings)	≥ 500

Environmental data	Requirements
Temperature range	-50 to +125 °C/-58 to +257 °F
Climatic category	IEC → 55/155/21
Thermal shock	MIL-STD-202, method 107, condition B
Moisture resistance	MIL-STD-202, method 106
Corrosion	salt spray test acc. to MIL-STD-202, method 101, condition B
Vibration	MIL-STD-202, method 204, condition B
Shock	MIL-STD-202, method 213, condition G

Material data		
Connector parts	Material	Plating
Bodies	brass	SUCOPLATE®
Pin contacts	brass	gold
Socket contacts	copper-beryllium alloy	gold
Crimp ferrules	copper	SUCOPLATE®
Insulators	ETFE (Tefzel)	
Gaskets	silicon rubber	

Some connectors may have a specification that differs from the above mentioned data.

The products are designed and guaranteed to pass the above mentioned test procedures. Any additional or different requirement arising from specific applications or environmental conditions which is not covered by these test procedures is subject to request.

¹⁾ Value considers maximum load of the cables without irreversible variations of specifications.

Series BNO - cable connectors

Straight cable plugs (male)

- Cable entry crimp
- Centre contact crimp or soldered

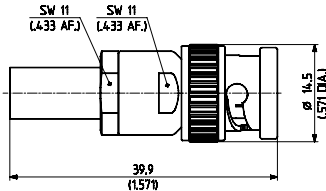

HUBER+SUHNER type	Item no.	Cable group (example)	Packaging	Assembly instruction	Crimp insert
11_BNO-0-4-1/133_NE	22541080	V1 (RG_108_A/U)	single	3083	76_Z0-4-8
11_BNO-0-4-1/133_NH	22649903		bulk 100 pcs.		

Right angle cable plug (male)

- Cable entry crimp
- Centre contact soldered

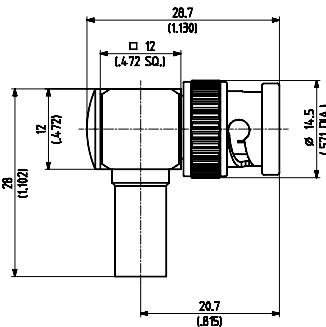

HUBER+SUHNER type	Item no.	Cable group (example)	Packaging	Assembly instruction	Crimp insert
16_BNO-0-4-1/133_NE	22643456	V1 (RG_108_A/U)	single	9042	C

Straight cable jacks (female)

- Cable entry crimp
- Centre contact crimp or soldered

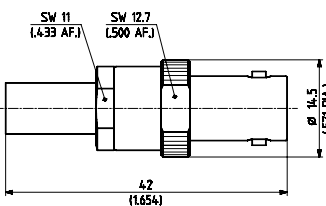

HUBER+SUHNER type	Item no.	Cable group (example)	Packaging	Assembly instruction	Crimp insert
21_BNO-0-4-1/133_NE	22541081	V1 (RG_108_A/U)	single	3083	76_Z0-4-8

Series BNO - cable connectors

Straight bulkhead cable jacks (female)

- Cable entry crimp
- Centre contact crimp or soldered

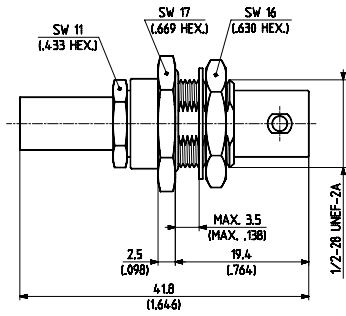

HUBER+SUHNER type	Item no.	Cable group (example)	Packaging	Assembly instruction	Mounting hole	Crimp insert
24_BNO-0-4-1/133_NE	22541086	V1 (RG_108_A/U)	single	9043	ML4	76_Z0-4-8

Series BNO - receptacles with solder end

Receptacles, jacks (female)

- Bulkhead mounted
- Without panel seal
- Front mounting

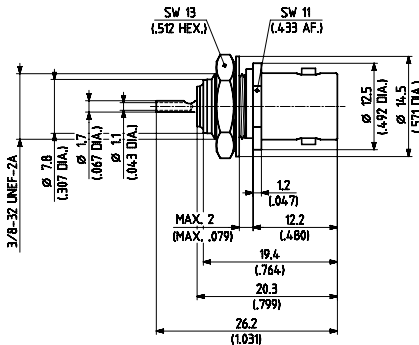

Fig. 1

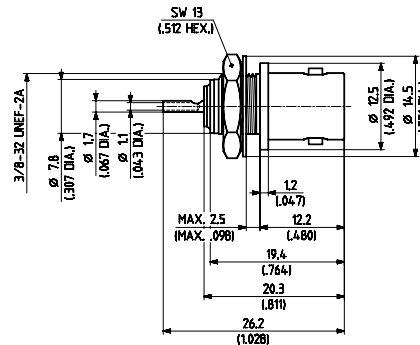

Fig. 2



HUBER+SUHNER type	Item no.	Packaging	Mounting hole	Fig.	Notes
22_BNO-0-0-1/133_NE	22541082	single	ML 3	1	max. panel thickness 2 mm/0.079 in
22_BNO-0-0-2/133_NE	22541083		ML 2	2	max. panel thickness 2.5 mm/0.098 in

- Panel mounted

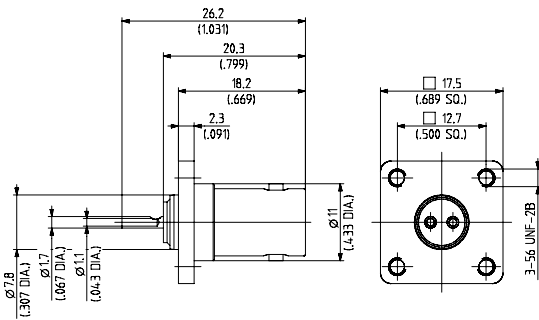

Fig. 1

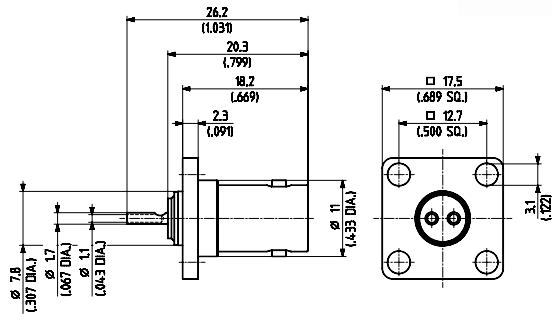

Fig. 2



HUBER+SUHNER type	Item no.	Packaging	Mounting hole	Fig.	Notes
23_BNO-0-0-1/133_NE	22543389	single	ML 6	1	flange with 4 threads ¹⁾
23_BNO-0-0-2/133_NE	22541085			2	flange with 4 holes

¹⁾ Mounting also possible with screws ISO M 2.5