

VECO VANSONIC ENTERPRISE CO., LTD.

8F., No.7, Lane 16, Sec.2, Szechwan Road, Panchiao, Taipei Hsien, TAIWAN.

TEL: +886-2-29626335

FAX: +886-2-29625220

E-MAIL: VANSONIC@MS4.HINET.NET

1.	MODEL:	40CS08KS -M75NA(Shining Mylar)			
2.	Dimension	Outer Diameter	40X40 mm.	Baffle Opening	32.8 mm.
		Height	Refer to Drawing.	Weight	5.2 Grams.
3.	Magnet	Materials	Rare Earth	Size	∅ 9.5x1.5 mm.
4.	Nominal Impedance	8	± 15 %	At	1500 Hz.
5.	Power Rating	Normal	200 mW.	Maximum	300 mW.
6.	Lowest Resonant Frequency	550	± 20 %		Hz.
7.	Output Sound Pressure Lever (S.P.L.)	75	± 3 db / 0.2 Watt	. 0.5 Meter.	
		Average at	800,	1000,	1200,
8.	Frequency Range	300	~ 9500 Hz.	Average SPL - 10 db.	
9.	Distortion	5 %	Maximum At	1000 Hz.	200 mW.
10.	Abnormal Sound Test	Must be Normal Tested By		1.3 Volts.	Sine Wave.
11.	Load Test	White Noise with Weighted Filter		1.3 Volts.(RMS)	24Hrs.
12.	Polarity	Diaphragm shall move Forward when Apply a Positive DC.			
		Current to the "+" or "Marked" Terminal.			

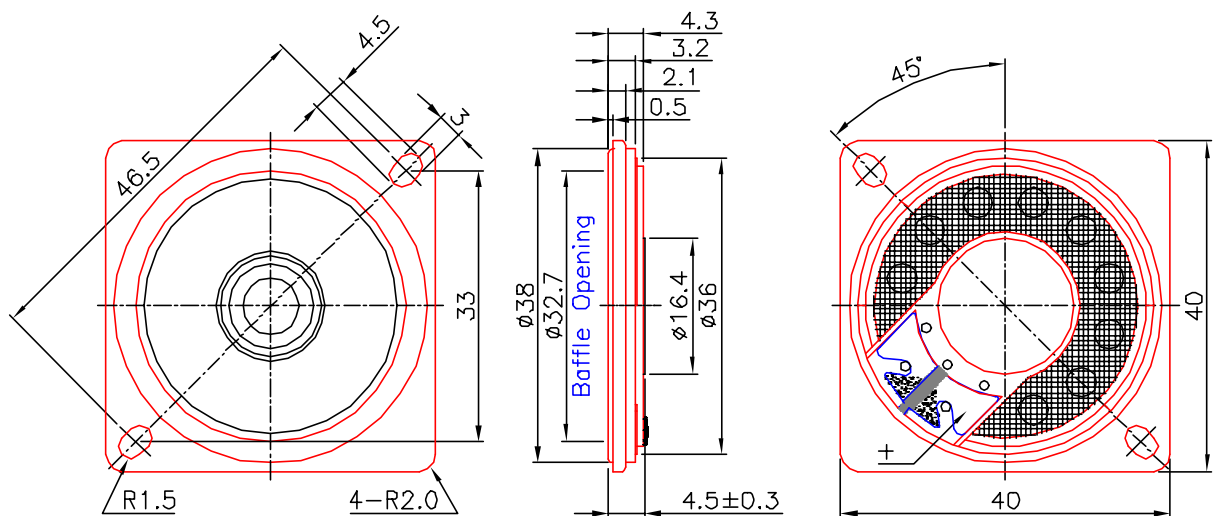

Unit : mm

Tolerance: ± 0.2 Excepted Specified

Housing Material: ABS

40CS08KS-75NA Vol:1.265V(0.2W) Dis:0.5M VANSONIC
X:1.0000kHz *Y:75.22dB ZA:Live Curve SSR Fund.

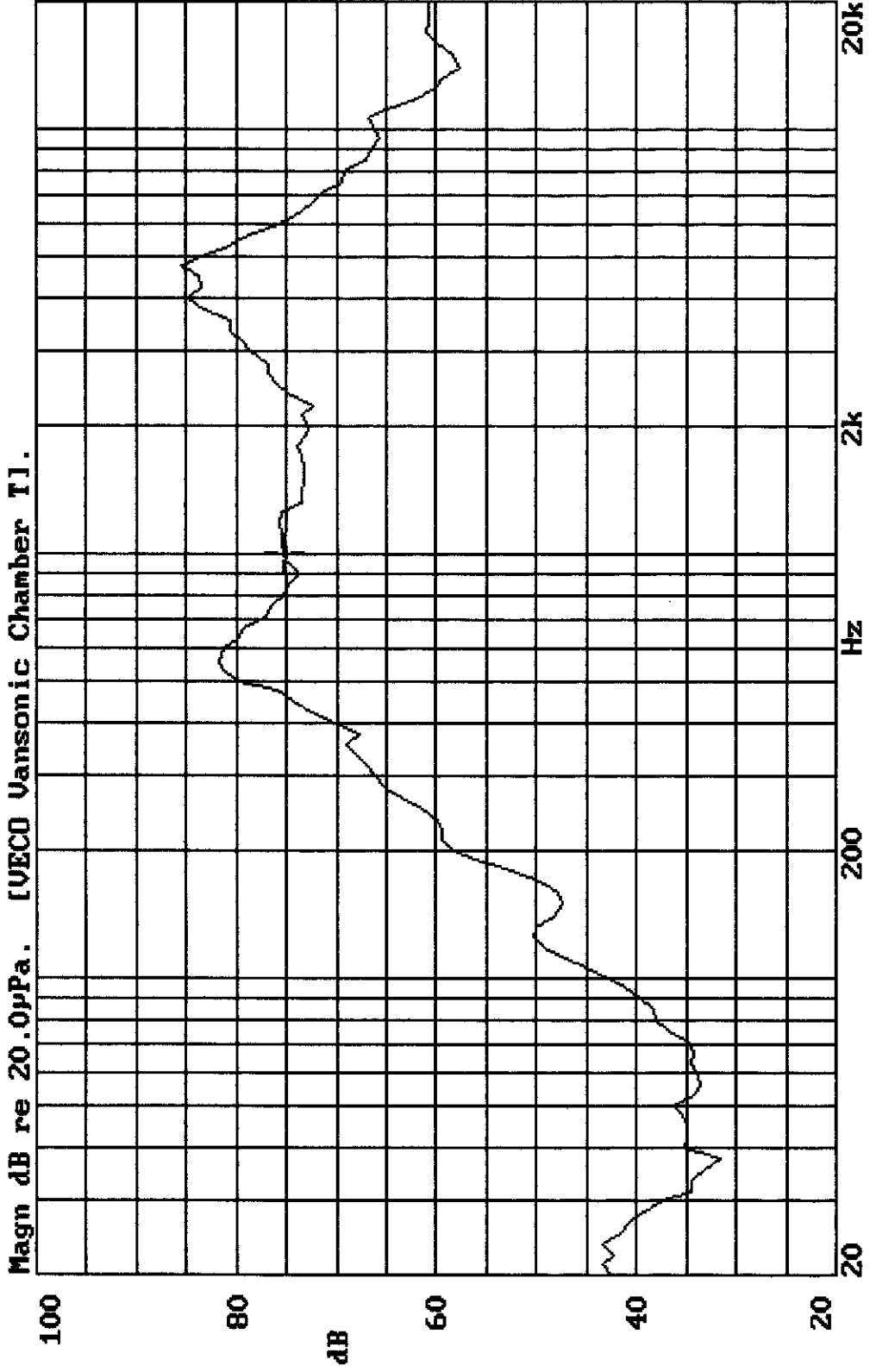

21-JUN-1999 14:09:33

Mode: SPEAKER

