

VECO VANSONIC ENTERPRISE CO.,LTD.

8F., No7, Lane16, Sec2, Szechwan Road, Panchiao, Taipei Hsien, TAIWAN.
 E-mail: Vansonic@ms4.hinet.net Homepage: <http://www.veco.com.tw>
 TEL: +886-2-962 6335 FAX: +886-2-962 5220n

1.	MODEL:	P15CR08GL DYNAMIC MICRO SPEAKER
2.	Dimension	Outer Diameter Φ 15 mm
		Height Refer to Fig 1 mm. Weight 1.3 Grams.
3.	Magnet	Materials NdFeB Size: Φ 7.5 x 0.9t mm.
4.	Impedance	8 Ω \pm 15 % At 1000 Hz.
5.	Power Rating	Normal 0.5 W. Max. 0.8 W
6.	Output Sound Pressure (S.P.L.)	84\pm 3 db / 0.5Watt · 0.3Meter, Measured by B&K Type 2012
		At 800, 1000, 1200 ,1500 HZ Average
7.	Resonance frequency	850 \pm 20% Hz at 1.0V measured by SUNLILAB® 7117C
8.	Frequency Range	500 ~ 20,000 Hz. Average SPL -10db Refer to Fig. 2
9.	Distortion	5 % Maximum at 1,500 Hz at 0.5W.
10.	Abnormal Sound Test	Must be Normal Tested By 2.0 Volts. Sine Wave.
11.	Load Test	White Noise With IEEE-219 Weighted filter 2.0 Volts(RMS.) 24hrs.
12.	Storage Temperature	- 40°C ~ +80°C
13.	Operating Temperature	- 30°C ~ +70°C

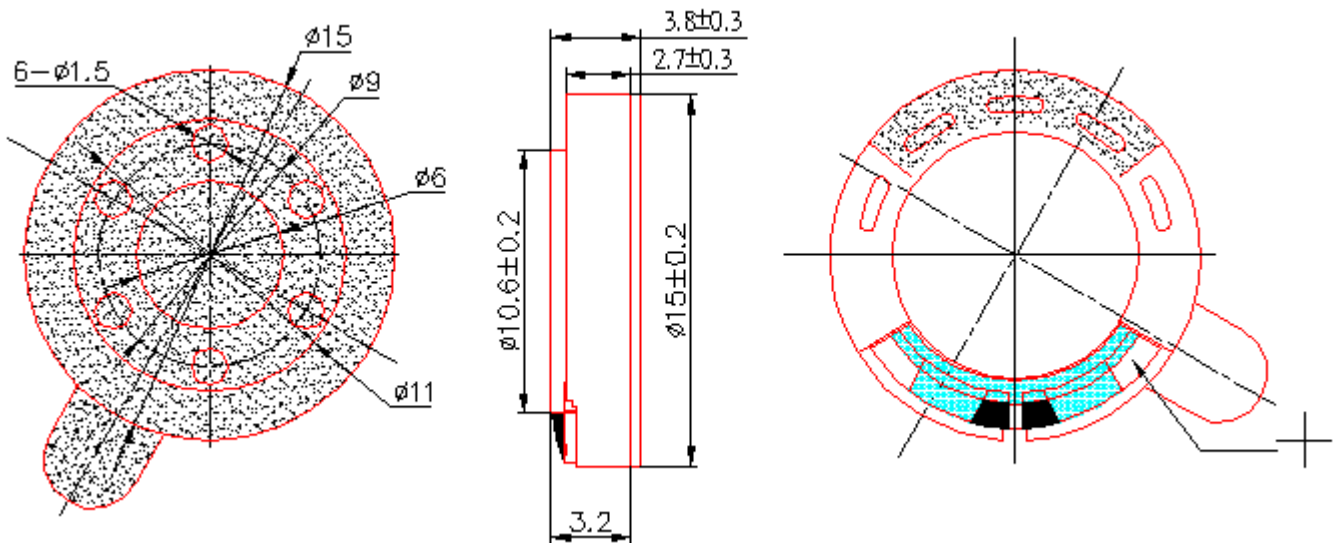
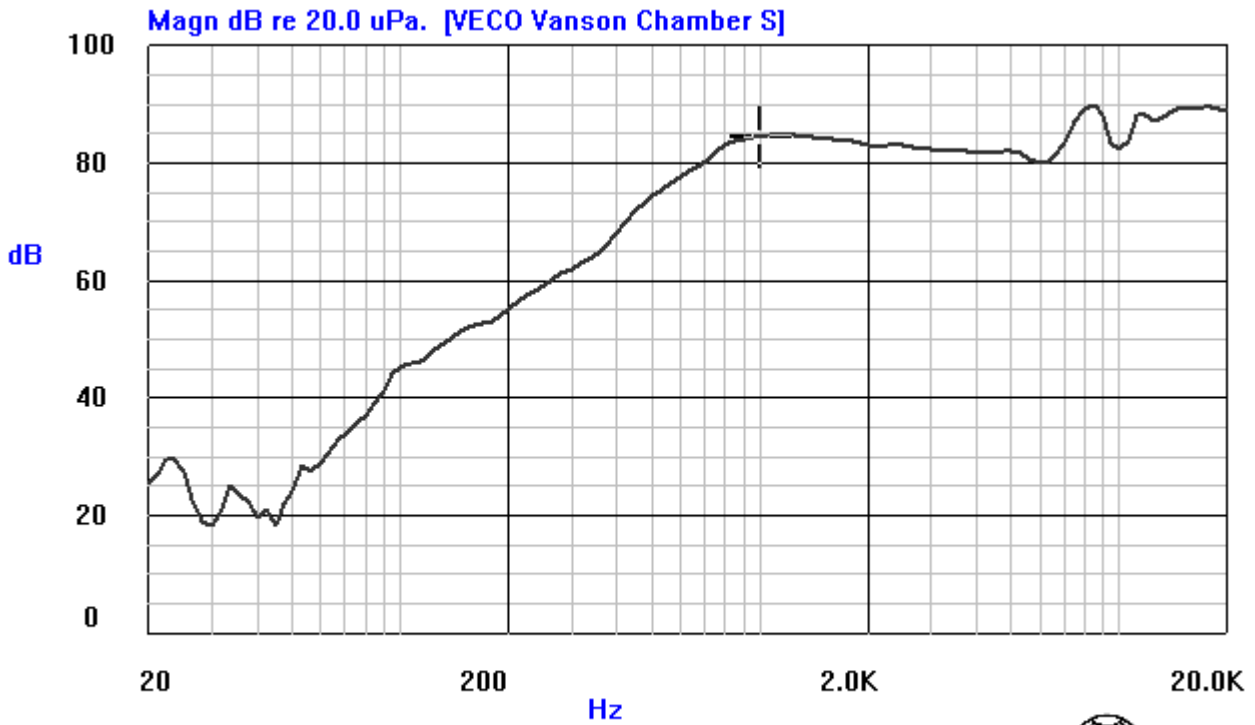

Fig.1

14.FrequencyResponse Curve

14.1 Speaker

Sound Pressure Level(SPL) : 84 ± 3 dB 0.5W/0.3M at (800,1k,1.2k,1.5k) AV



Current Curve: 0 X: 1000 Hz Y: 84.55 dB
Time[Y/M/D H:M:S]: 2004/ 5/ 7 3:19: 7



INPUT: 0.5W
MIC DIST: 0.3M
BAFFLE: IEC6028-5

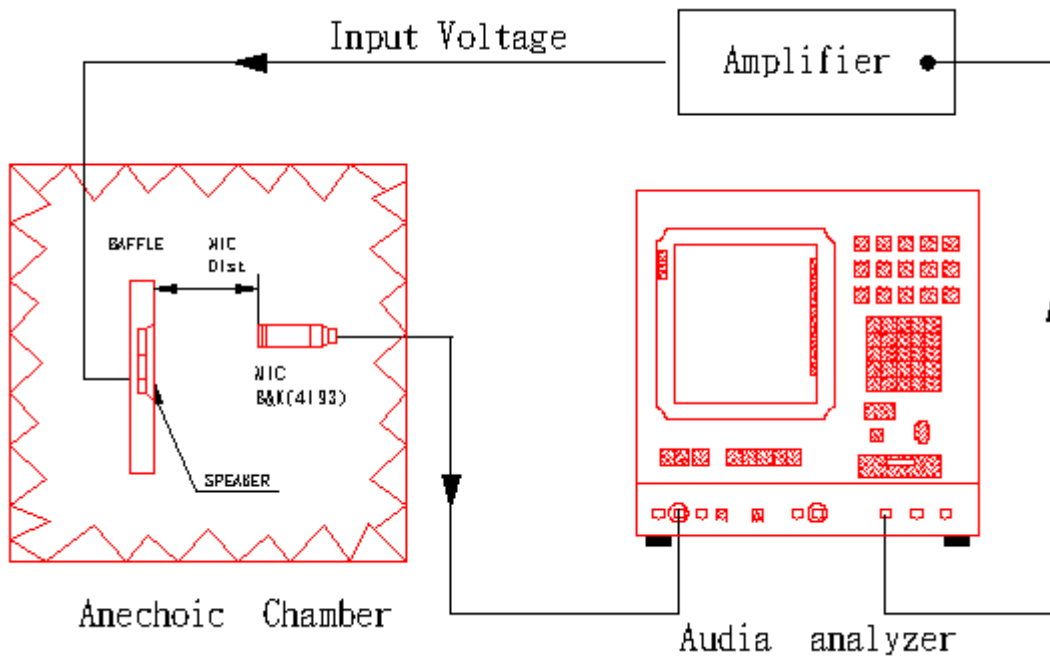

Fig.2

15.Environment Test

15.1 Environment test – High temperature.

After exposure the speaker in the $+ 80 \pm 3 \text{ }^\circ\text{C}$ chamber for 24 hours, then leave the speaker at room temperature for 1 hour, the SPL should not deviate by $\pm 3 \text{ db}$, compare with pre-test measurement.

15.2 Environment test - Low temperature.

After exposure the speaker in the $- 40 \pm 3 \text{ }^\circ\text{C}$ chamber for 24 hours, then leave the speaker at room temperature for 1 hour, the SPL should not deviate by $\pm 3 \text{ db}$, compare with pre-test measurement.

15.3 Environment test-Temperature cycle.

After exposure the speaker in the chamber, temperature cycle setting as below shows, SPL should not deviate by $\pm 4\text{db}$,compare with pre-test measurement.

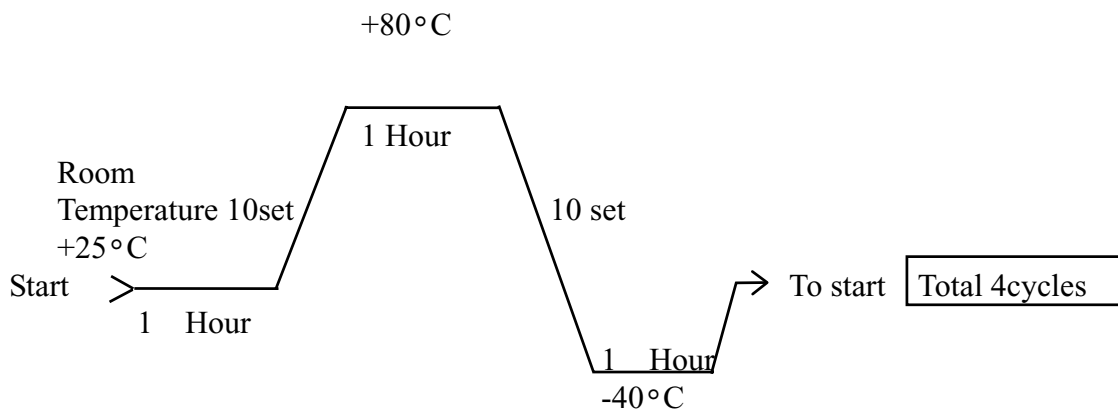

15.4 Environment test – Humidity.

After exposure the speaker in the $+ 40 \pm 3 \text{ }^\circ\text{C}$, relative humidity $90\% \sim 95\%$ chamber for 24 hours, then leave the speaker at room temperature for 6 hours, the SPL should not deviate by $\pm 3\text{db}$, compare with pre-test measurement.