

MGAFF-U120-01

Specification

Part Series	GNSS Receiver Module
Part Number	MGAFF-U120-01
Version	V0.1

Contents

1. Overall	3
2. Feature	3
3. Application	4
4. Pin Configuration and Function	5
4.1 Pin Configuration (Top View)	5
4.2 Pin Function	5
5. Performance	6
5.1 RF performance	6
5.2 Digital performance	6
6. Application	7
6.1 with passive antenna	7
6.2 with active antenna	7
6.3 Wakeup and Notify function	8
7. Electrical Specification	9
7.1 Absolution Rating	9
7.2 ESD Rating	9
7.3 Recommended Operation Conditions	9
7.4 Power consumption	9
8. Mechanical Specification	10
8.1 Outline Dimensions	10
8.2 PCB land pattern dimensions	11
9. Ordering Information	12
10. INPAQ relative and peripheral product	12
11. Version	12

1. Overall

The MGAFF-U120 series is compact GNSS receiver module. The module support L1 band GNSS signal and multi system, GPS, GLONASS, Galileo, BeiDou and QZSS. The multi-system GNSS receiver will increase the visible satellite and improve navigate performance, fast acquisition time and position accuracy.

The MGAFF-U120 series provide fast TTFB time, acquisition time and up to 47 satellite channel. The module integrates a high rejection filter. That will reduce noise interface and enhance anti-jamming performance.

The MGAFF-U120 series is excellent and easy to use in navigation and position application. The package with stamp hole and compact, that is easy to mount on system board.

2. Feature

- L1 band GNSS receiver
- Support GPS, GLONASS, Galileo, BeiDou, QZSS
 - Support Max. 47 channel
- Time to First Fixed (TTFB)
- Max 10Hz update rate
- Integrate high rejection filter (SAW filter)
- Integrate DC blocking in RFin port
- Signal voltage supply
- UART interface
- Ultra-low power consumption
- ESD protection
- Ultra-compact module package (1010)
- Support SMD process
- RoSH/REACH Compliance



3. Application

- Personal position and navigation
- IoT
- Smart city

Simplified Schematic and application

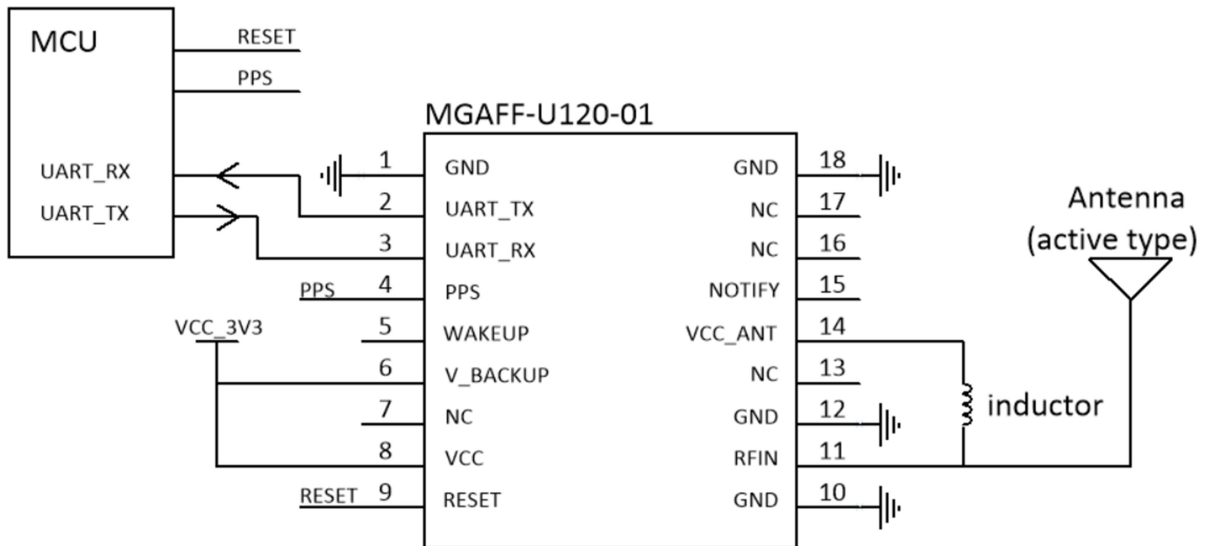

4. Pin Configuration and Function

4.1 Pin Configuration (Top View)

GND	<input type="checkbox"/>	10	9	<input type="checkbox"/>	RESET
RFIN	<input type="checkbox"/>	11	8	<input type="checkbox"/>	VCC
GND	<input type="checkbox"/>	12	7	<input type="checkbox"/>	NC
NC	<input type="checkbox"/>	13	6	<input type="checkbox"/>	V_BACKUP
VCC_ANT	<input type="checkbox"/>	14	5	<input type="checkbox"/>	WAKEUP
NOTIFY	<input type="checkbox"/>	15	4	<input type="checkbox"/>	PPS
NC	<input type="checkbox"/>	16	3	<input type="checkbox"/>	UART_RX
NC	<input type="checkbox"/>	17	2	<input type="checkbox"/>	UART_TX
GND	<input type="checkbox"/>	18	1	<input type="checkbox"/>	GND

4.2 Pin Function

PIN		Type	Description
Number	Name		
2	UART_TX	O	UART transmit, 1.8V level
3	UART_RX	I	UART receive, 1.8V level
3	PPS	O	1PPS signal, 1.8V level
5	WAKEUP	I	Host wake up GNSS chip, 1.8V level. Internal pull high. Low active. Float this pin, if no use this function.
6	V_BACKUP	P	Backup Voltage supply
8	VCC	P	Voltage supply
11	RFIN	I	RF input, internal DC block
14	VCC_ANT	P	Voltage Supply for external active antenna
15	NOTIFY	O	GNSS chip wake up Host & Notify data ready. 1.8V level. Internal pull low. High active. Float this pin, if no use this function.
1, 10, 12, 18	GND	GND	Ground pin. Connect to system ground
7, 13, 14, 16, 17	NC	NC	No connect to internal circuit. Can be float.

5. Performance

5.1 RF performance

Parameter	Specifications
Frequency (MHz)	GPS: L1 C/A, 1575.42 GLONASS: L1, 16023.5625 Galileo: E1,1575.42 BeiDou: B1, 1561.098 QZSS: L1, 1575.42
Channel	47
Timing Accuracy	1pps, +/-10ns
Update rate	1Hz
Sensitivity	Tracking: -163 dBm Acquisition: -146 dBm
TTF	Host start: 1 sec Cold start: 28 sec
Position Precision (CEP)	2 m
Max input level	-40dBm

5.2 Digital performance

Parameter	Specifications
Update rate	1Hz
UART	9600 bps
Protocols	NMEA 0183

6. Application

6.1 with passive antenna

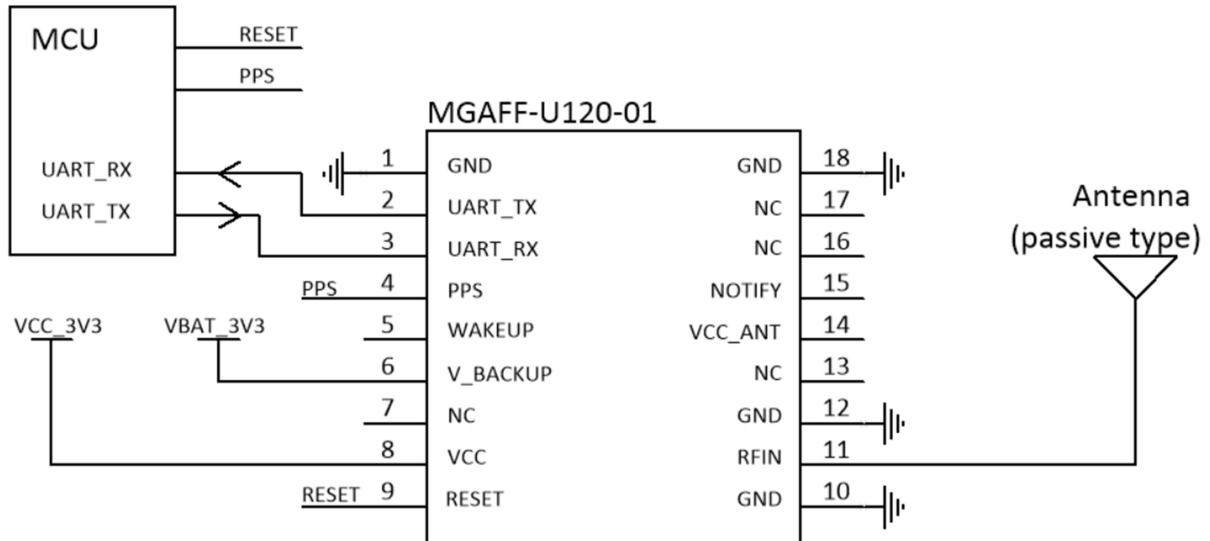

6.2 with active antenna

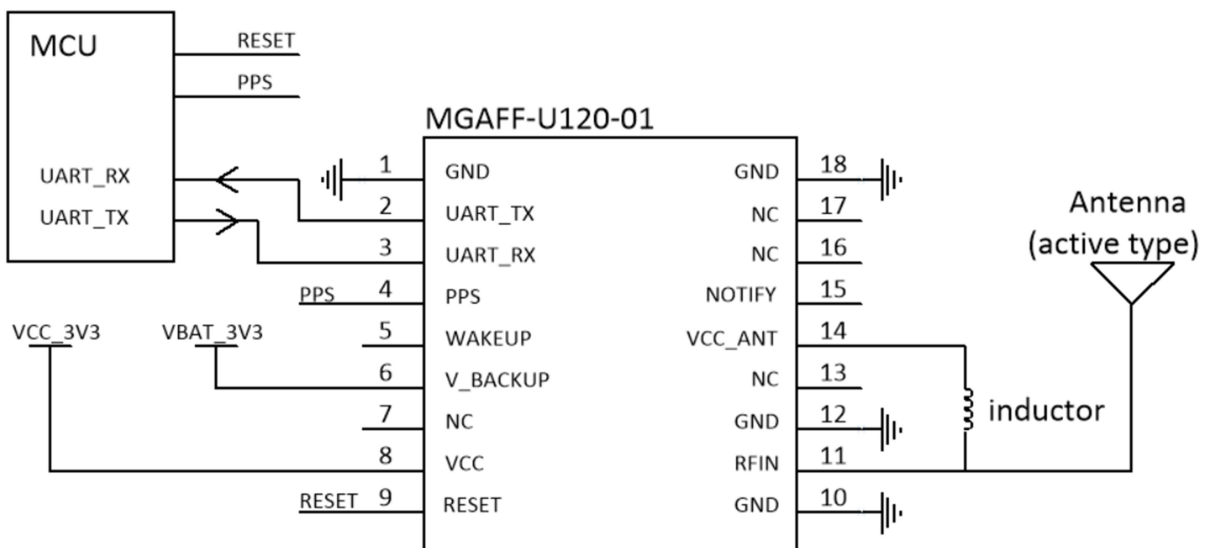

Choose Inductor, 18nH~33mH, and consider the current of active antenna.

6.3 Wakeup and Notify function

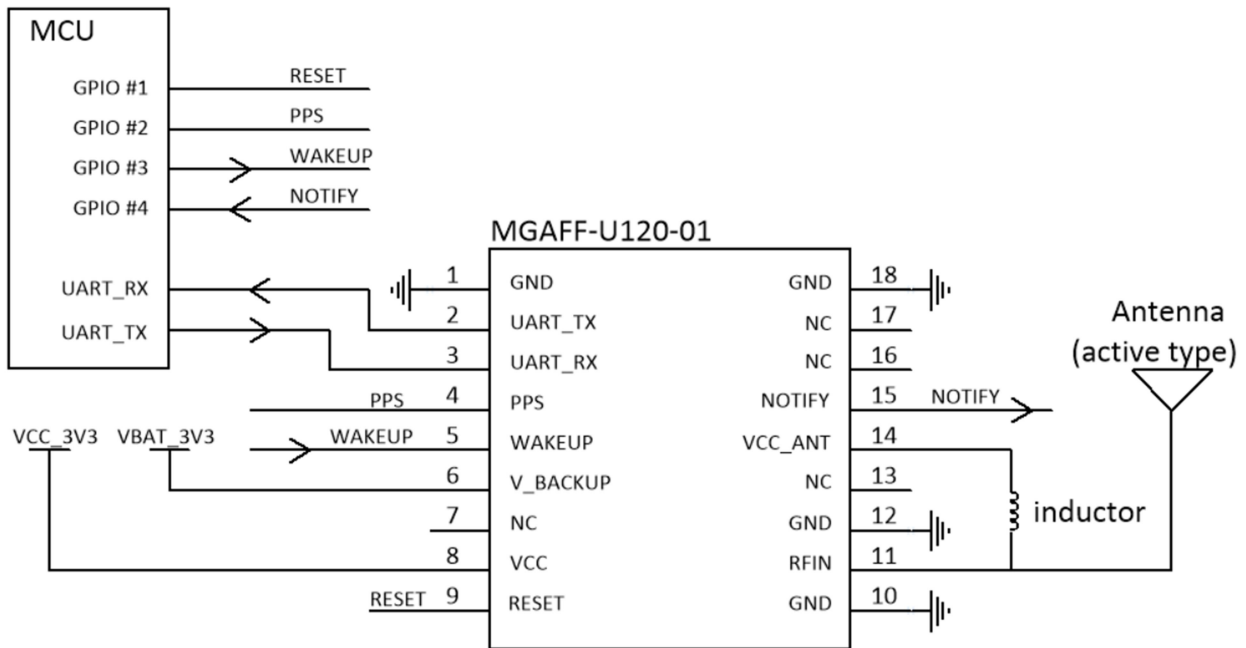

7. Electrical Specification

7.1 Absolution Rating

Parameter	Description	Min	Max	Unit
VCC	Voltage input		5.5	V
V_BACKUP	Backup voltage input		5.5	V
RF_IN	Max RF input level		-40	dBm

7.2 ESD Rating

Mode	JEDEC Specification	Min	Max	Unit
Human body model	JESD22-A114-F	-2000	2000	V
Charge device model	JESD22-C101-D	-500	500	V

7.3 Recommended Operation Conditions

Parameter	Description	Min	Max	Unit
VCC	Voltage input	3	5	V
V_BACKUP	Backup voltage input	3	5	V
V-IH	IO, UART	1.2	2.1	V
V-IL	IO, UART	-0.3	0.6	V
V-OH	IO, UART	1.4		V
V-OL	IO, UART		0.4	V
Temp-op	Operation temperature	-40	+85	°C
Temp-st	Storage temperature	-40	+105	°C

7.4 Power consumption

Parameter	Description	typical	Unit
Pcon	Power consumption	65	mW

8. Mechanical Specification

8.1 Outline Dimensions

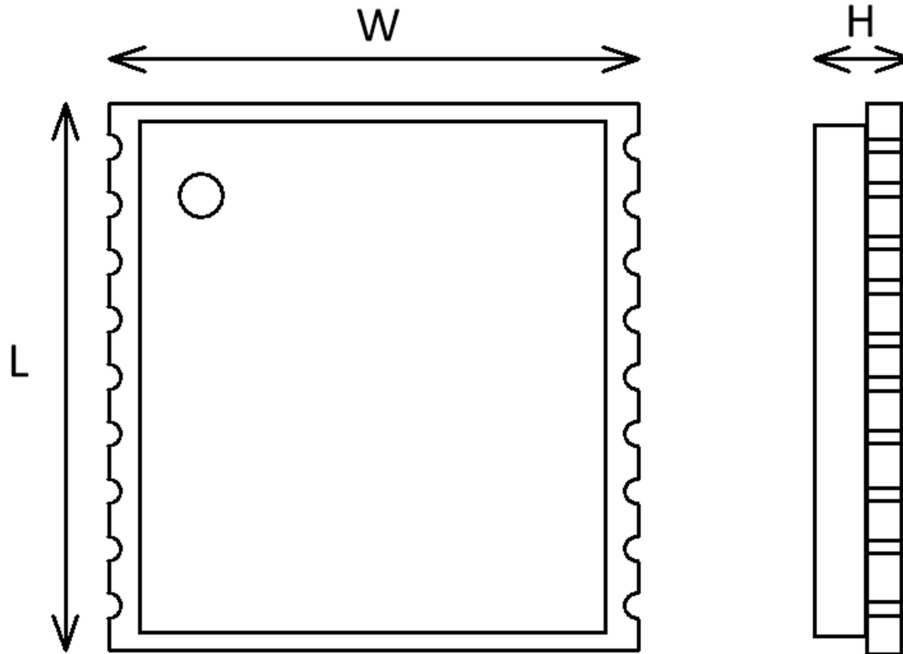

Symbol	Min (mm)	Normal (mm)	Max (mm)
W	9.5	9.7	9.9
L	9.9	10.1	10.3
H	2.4	2.5	2.7

8.2 PCB land pattern dimensions

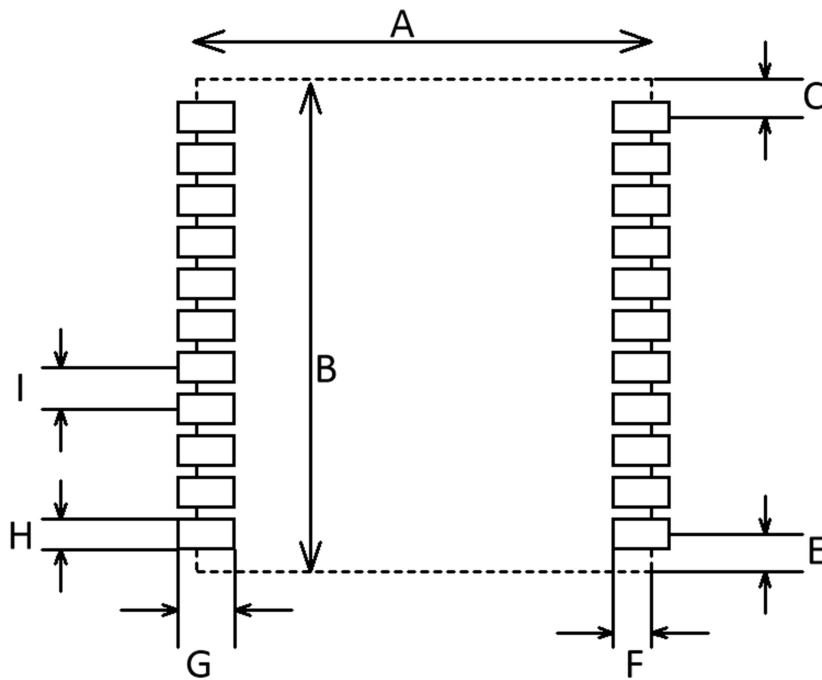

Symbol	Min (mm)	Normal (mm)	Max (mm)
A	9.5	9.7	9.9
B	9.9	10.1	10.3
C	0.6	0.65	0.7
E	0.6	0.65	0.7
F	0.5	0.6	0.7
G	0.7	0.8	0.9
H	0.7	0.8	0.9
I	1.0	1.1	1.2

9. Ordering Information

Part Number	Description
MGAFF-U120-01	1612 SMD type module
MGAFF-U120-01-EV	Evaluation Board

10. INPAQ relative and peripheral product

Series	Part Number	Description
GNSS receiver module	MGAFF-U120-01	Basic GNSS receiver module
GNSS patch antenna	*	Active patch antenna
GNSS patch antenna	*	Passive patch antenna

NOTE

* contact with INPAQ sales for detail antenna specification.

11. Version

Version	Date	Description
V0.1	2024.05.24	Initial Release