

REVISIONS					
REV	ECO	DESCRIPTION	DATE	BY	APPR
A1	--	FIRST RELEASED	Apr.05,2016	Drack	Tommy
A2	--	UPDATE NOTES	Jun-21-2017	Nick	Tommy

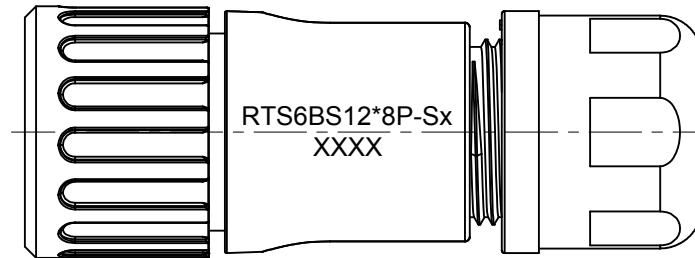
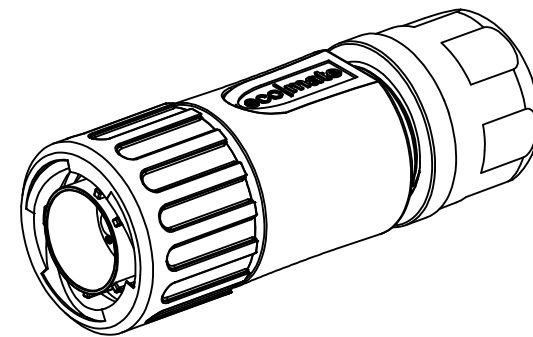
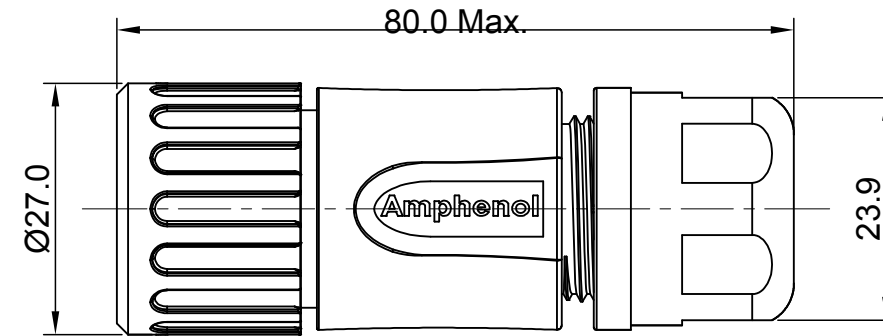
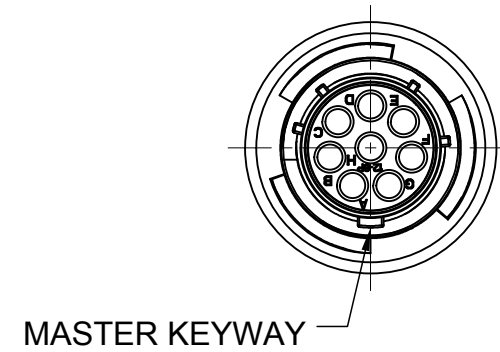

NOTES : (UNLESS OTHERWISE SPECIFIED)

1. MATERIAL :

- SHELL : THERMOPLASTIC , UL94 V-0.
- INSERT : THERMOPLASTIC , UL94 V-0.
- COUPLING NUT : THERMOPLASTIC , UL94 V-0.
- O-RING : NBR OR SILICONE RUBBER.
- WASHER : SILICONE RUBBER.
- BACK SHELL : THERMOPLASTIC , UL94 V-0.
- CLAMP NUT : THERMOPLASTIC , UL94 V-0.
- CLAMP RING : THERMOPLASTIC , UL94 V-0.
- CABLE SEAL : EPDM.

2. SPECIFICATIONS :

- 2.1, RATED CURRENT : 13A (MAX).
- 2.2, RATED VOLTAGE : 500V(AC/DC).
- 2.3, OPERATING TEMPERATURE : SEE TABLE.
- 2.4, DIELECTRIC WITHSTANDING VOLTAGE : LESS THAN 2 MILLIAMPS CURRENT LEAKAGE@2000 VOLTS AC.
- 2.5, INSULATION RESISTANCE : 5000 MEGOHMS MIN.
- 2.6, IP-CLASS : IP67 AND IP69K.
- 2.7, MATING CYCLES DURABILITY : 500 CYCLES MIN.
- 2.8, RoHS COMPLIANT.

3. SUITABLE CONTACTS : 16# CONTACT.

4. ALL DIMENSIONS ARE FOR REFERENCE USE ONLY.

KEY	PART NUMBER		CABLE OD RANGE
	-40°C ~ 105°C	-40°C ~ 125°C	
N	RTS6BS12N8P-S1	RTS6BS12N8P03-S1	6.0~9.0mm
	RTS6BS12N8P-S2	RTS6BS12N8P03-S2	8.5~12.0mm

QUANTITY	PART NUMBER	DESCRIPTION	ITEM
MATERIALS LIST			
UNLESS OTHERWISE SPECIFIED		SIGNATURES	
1) All dimensions are in metric (mm).		DRAWN: Nick Jun-21-2017	
2) PL DEC ±0.15 as per spec		CHECKED: Tod Jun-21-2017	
3) Note reference = X		ENGINEER: Tommy Jun-21-2017	
MATERIAL SPECIFICATIONS:		APPROVAL: Tommy Jun-21-2017	
PROCESS SPECIFICATIONS:		CUSTOMER:	
NEXT ASSY:		THIS DRAWING IS SUPPLIED FOR INFORMATION ONLY. DESIGN FEATURES, SPECIFICATIONS AND PERFORMANCE DATA SHOWN HEREON ARE THE PROPERTY OF THE AMPHENOL CORPORATION. NO RIGHTS OF REPRODUCTION ARE IMPLIED. ALL DIMENSIONS ARE SUBJECT TO NORMAL MANUFACTURING VARIATIONS.	
		Sine Systems - www.amphenol-sine.com 44724 Morley Drive Clinton Township, MI 48036	
		ECO-MATE, PLUG, STRAIGHTER, 8POS, PIN CONTACT, SIZE 12	
SIZE	TYPE	DWG NO:	REVISION
B	C-	RTS6BS12*8Pxx-Sx	A2
SCALE	NONE		SHEET 1 OF 1

TITLE: ECO-MATE, PLUG, STRAIGHTER, 8POS, PIN CONTACT, SIZE 12 DWG NO: RTS6BS12*8Pxx-Sx REV: A2 SH: 1 OF: 1