

REVISIONS					
REV	ECO	DESCRIPTION	DATE	BY	APPR
A1	--	RELEASED DRAWING	Aug-10-2016	Ben	Tommy
A2	--	UPDATE NOTES	Jun-20-2017	Nick	Tommy

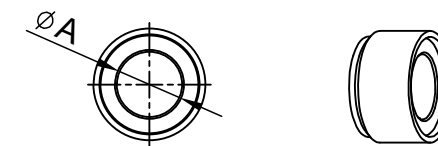
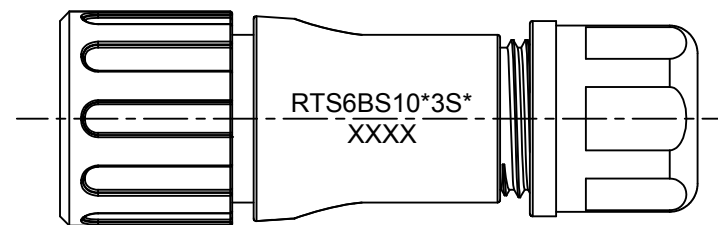
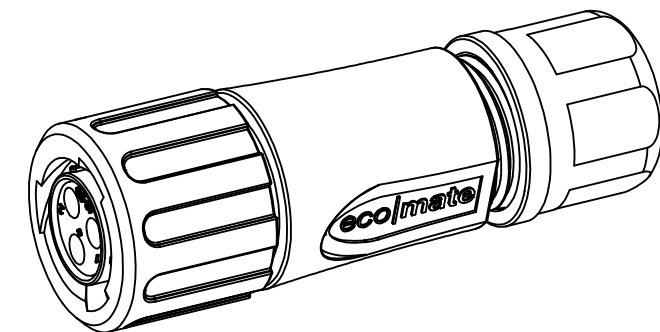
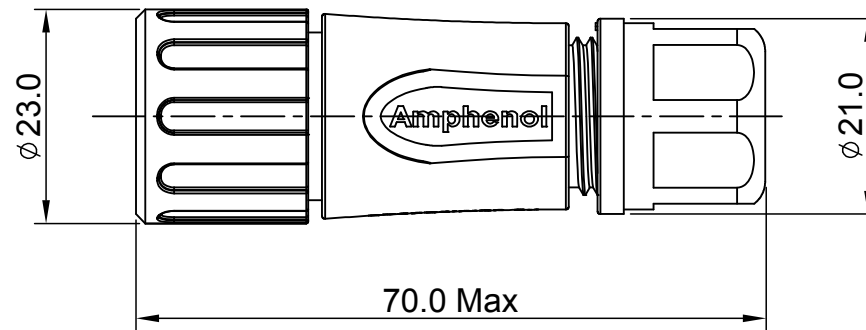
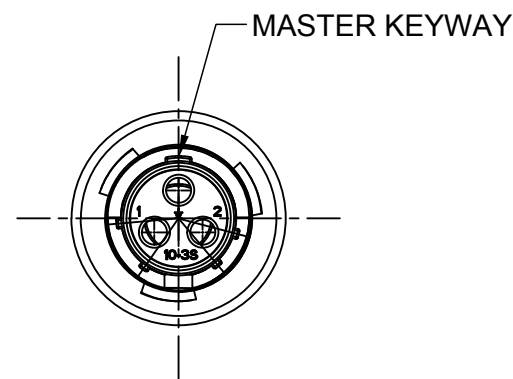

NOTES : (UNLESS OTHERWISE SPECIFIED)

- MATERIAL :
SHELL : THERMOPLASTIC , UL94 V-0.
INSERT : THERMOPLASTIC , UL94 V-0.
COUPLING NUT : THERMOPLASTIC , UL94 V-0.
O-RING : NBR/SILICONE RUBBER.
WASHER : SILICONE RUBBER.
BACK SHELL : THERMOPLASTIC , UL94 V-0.
CLAMP NUT : THERMOPLASTIC , UL94 V-0.
CLAMP RING : THERMOPLASTIC , UL94 V-0.
CABLE RING : EPDM.
- SPECIFICATIONS :
2.1 RATED CURRENT : 13A (MAX).
2.2 RATED VOLTAGE : 500V(AC/DC).
2.3 OPERATING TEMPERATURE : SEE TABLE .
2.4 DIELECTRIC WITHSTANDING VOLTAGE : LESS THAN 2 MILLIAMPS CURRENT LEAKAGE@2000 VOLTS AC.
2.5 INSULATION RESISTANCE : 5000 MEGOHMS MIN.
2.6 IP--CLASS : IP67 AND IP69K.
2.7 MATING CYCLES DURABILITY : 500 CYCLES MIN.
2.8 RoHS COMPLIANT.
- SUITABLE CONTACTS : 16# CONTACT.
- ALL DIMENSIONS ARE FOR REFERENCE USE ONLY.

DIMENSION ϕA	CABLE OD RANGE
7.0MM	4.0-6.5MM
8.8MM	5.0-8.8MM

KEY	PART NUMBER	
	-40°C ~ +105°C	-40°C ~ +125°C
N	RTS6BS10N3S	RTS6BS10N3S03

QUANTITY	PART NUMBER	DESCRIPTION	ITEM
MATERIALS LIST			
UNLESS OTHERWISE SPECIFIED 1) All dimensions are in metric(mm). 2) Tolerances are as follows: 1 PL DEC ±0.30 Fractions ±1/64 2 PL DEC ±0.15 Angles ±1° 3 PL DEC ±0.08		SIGNATURES DATE DRAWN: Nick Jun-20-2017 CHECKED: Tod Jun-20-2017 ENGINEER: APPROVAL: Tommy Jun-20-2017 CUSTOMER:	
MATERIAL SPECIFICATIONS:		 Sine Systems - www.amphenol-sine.com 44724 Morley Drive Clinton Township, MI 48036 ECO-MATE,PLUG,BACK SHELL, SIZE 10,3POS,SOCKET.	
PROCESS SPECIFICATIONS:			
NEXT ASSY:		THIS DRAWING IS SUPPLIED FOR INFORMATION ONLY. DESIGN FEATURES, SPECIFICATIONS AND PERFORMANCE DATA SHOWN HEREON ARE THE PROPERTY OF THE AMPHENOL CORPORATION. NO RIGHTS OF REPRODUCTION ARE IMPLIED. ALL DIMENSIONS ARE SUBJECT TO NORMAL MANUFACTURING VARIATIONS.	SIZE: B TYPE: C- DWG NO: RTS6BS10*3S* REVISION: A2 SCALE: NONE SHEET 1 OF 1

TITLE: ECO-MATE,PLUG,BACK SHELL,SIZE 10,3POS,SOCKET. DWG NO: RTS6BS10*3S* REV: A2 SH: 1 OF: 1