

REVISIONS					
REV	ECO	DESCRIPTION	DATE	BY	APPR
B1	-	RELEASED DRAWING	JUN-20-2014	BEN	TOMMY

15/16-20 UNEF THREAD

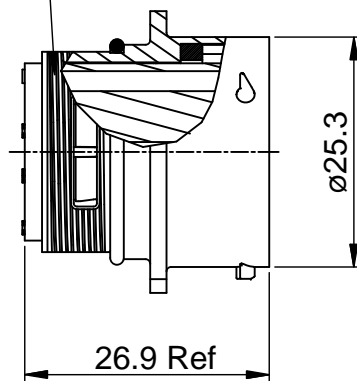

MASTER KEYWAY

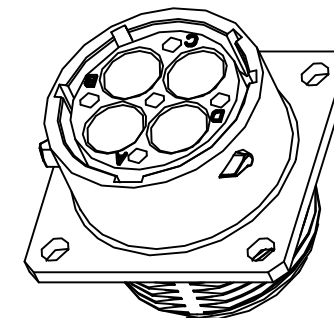
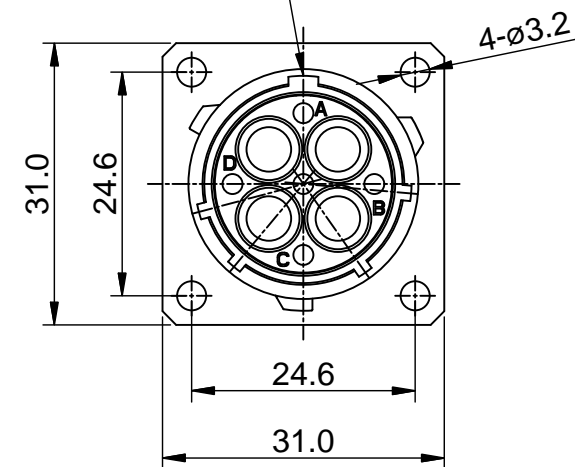

NOTES : (UNLESS OTHERWISE SPECIFIED)

- MATERIAL :  
SHELL : ZINC ALLOY , NICKEL PLATED.  
INSERT : THERMOPLASTIC , UL94 V-0.  
SEAL GASKET : NBR.  
O-RING : NBR.
- SPECIFICATIONS :  
2.1 RATED CURRENT : 45A (MAX).  
2.2 RATED VOLTAGE : 500V ( AC/DC ) .  
2.3 OPERATING TEMPERATURE : -40°C ~ +105°C.  
2.4 DIELECTRIC WITHSTANDING VOLTAGE : LESS THAN  
2 MILLIAMPS CURRENT LEAKAGE@2000 VOLTS AC.  
2.5 INSULATION RESISTANCE : 5000 MEGOHMS MIN.  
2.6 IP--CLASS : IP67.  
2.7 MATING CYCLES DURABILITY : 500 CYCLES MIN.  
2.8 ROHS COMPLIANT.
- SUITABLE CONTACTS : 8# CONTACTS.
- ALL DIMENSIONS ARE FOR REFERENCE USE ONLY.

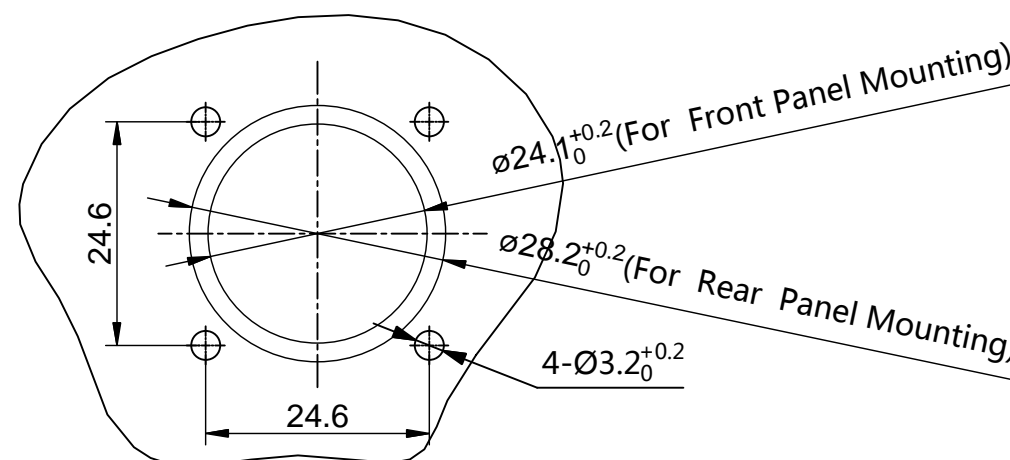

PANEL CUT OUT REFERENCE

KEY POS	PART NUMBER
N	RT00164PNH
W	RT00164PWH
X	RT00164PXH
Y	RT00164PYH
Z	RT00164PZH

QUANTITY	SEE PART NUMBER CHART PART NUMBER	DESCRIPTION	ITEM
<b>MATERIALS LIST</b>			
UNLESS OTHERWISE SPECIFIED 1) All dimensions are in metric (mm). 2) Tolerances are as follows: 1 PL DEC ±0.30 2 PL DEC ±0.15 3 PL DEC ±0.08 Fractions ±1/64 Angles ±1° 3) Note reference =		<b>Amphenol</b> Sine Systems - www.amphenol-sine.com 44724 Morley Drive Clinton Township, MI 48036	
MATERIAL SPECIFICATIONS:  PROCESS SPECIFICATIONS:  NEXT ASSY:		SIGNATURES: DRAWN: ARROW, DATE: JUN-20-2014 CHECKED: ENGINEER: APPROVAL: CUSTOMER: THIS DRAWING IS SUPPLIED FOR INFORMATION ONLY. DESIGN FEATURES, SPECIFICATIONS AND PERFORMANCE DATA SHOWN HEREON ARE THE PROPERTY OF THE AMPHENOL CORPORATION. NO RIGHTS OF REPRODUCTION ARE IMPLIED. ALL DIMENSIONS ARE SUBJECT TO NORMAL MANUFACTURING VARIATIONS.	
SIZE: B C- SCALE: NONE		DWG NO: RT00164P*H REVISION: B1 SHEET 1 OF 1	

TITLE: ECO-MATE RECEPTACLE SIZE 16,4POS,PIN  
DWG NO: RT00164P\*H  
REV: B1  
SH: 1  
OF: 1

**ecomate® RM/RSSM/Aquarius™ - Contact Size 3.6mm (1604 Insert Arrangement) Options**

Crimp Contacts, 1604 Insert Arrangement, Machined					
Part Number		AWG	Wire Range (mm <sup>2</sup> )	For Use w Endcap	Plating
Male	Female				
MP10A23T	MS10A23T	12-10	3.0 - 6.0	Yes	Tin
MP10A23S	MS10A23S	12-10	3.0 - 6.0	Yes	Silver
MP10A23F	MS10A23F	12-10	3.0 - 6.0	Yes	Gold Flash
MP10A23G5	MS10A23G5	12-10	3.0 - 6.0	Yes	Gold 5μ"
MP10S23G10	MS10A23G10	12-10	3.0 - 6.0	Yes	Gold 10μ"
MP10A23G15	MS10A23G15	12-10	3.0 - 6.0	Yes	Gold 15μ"
MS10A23G30	MS10A23G30	12-10	3.0 - 6.0	Yes	Gold 30μ"

Tooling, Machined	
Part Number	Description
QXRT08	Contact Extraction Tool, # 8 (Ø 3.6mm) Contact
M300BT	Hand Crimper
WA27-300BT-EP	Pneumatic Crimper
TP968	Locator M3200BT and WA27-300BT-EP

Plating Options	
Symbol	Plating
T	Tin Plating Over Nickel
S	Silver Plating Over Nickel
F	Gold Plated
G5	Gold Plated (Thickness 5μ")
G10	Gold Plated (Thickness 10μ")
G15	Gold Plated (Thickness 15μ")
G30	Gold Plated (Thickness 30μ")