

REVISIONS					
REV	ECO	DESCRIPTION	DATE	BY	APPR
A1	--	RELEASED DRAWING	Mar-18-2016	Ben	Tommy
A2	--	UPDATE NOTES	Jun-20-2017	Nick	Tommy

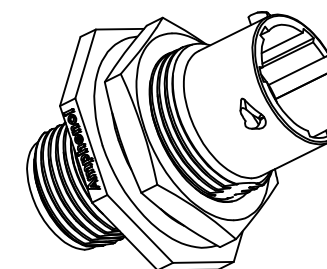

NOTES : (UNLESS OTHERWISE SPECIFIED)

1. MATERIAL :
 - SHELL : THERMOPLASTIC , UL94 V-0.
 - INSERT : THERMOPLASTIC , UL94 V-0.
 - O-RING : NBR/SILICONE RUBBER.
 - SEAL GASKET : NBR/SILICONE RUBBER.
 - JAM NUT : ALUMINIUM ALLOY , BLACK ANODIZING.
2. SPECIFICATIONS :
 - 2.1 RATED CURRENT :
 - 2.1.1 STAMPED CONTACT 5A (MAX).
 - 2.1.2 MACHINED CONTACT 7.5A (MAX).
 - 2.2 RATED VOLTAGE : 250V(AC/DC).
 - 2.3 OPERATING TEMPERATURE : SEE TABLE.
 - 2.4 DIELECTRIC WITHSTANDING VOLTAGE : LESS THAN 2 MILLIAMPS CURRENT LEAKAGE@1500 VOLTS AC.
 - 2.5 INSULATION RESISTANCE : 5000 MEGOHMS MIN.
 - 2.6 IP--CLASS : IP67 AND IP69K.
 - 2.7 MATING CYCLES DURABILITY : 500 CYCLES MIN.
- 2.8 RoHS COMPLIANT.
3. SUITABLE CONTACTS : 20# CONTACT.
4. ALL DIMENSIONS ARE FOR REFERENCE USE ONLY.

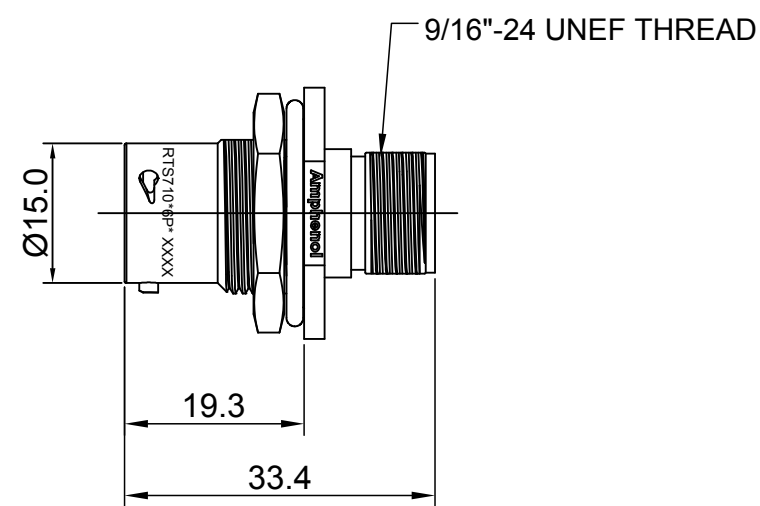
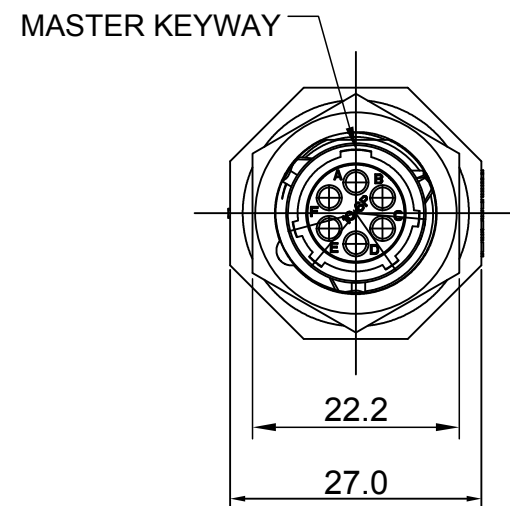
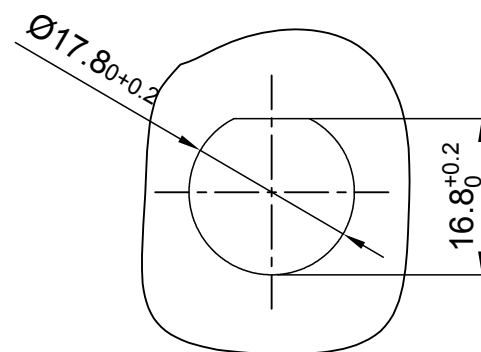

PANEL CUT OUT REFERENCE

KEY	PART NUMBER	
		-40°C ~ 105°C
N	RTS710N6P	RTS710N6P03

QUANTITY	PART NUMBER	DESCRIPTION	ITEM
MATERIALS LIST			
UNLESS OTHERWISE SPECIFIED		Amphenol	
1) All dimensions are in metric (mm).		Sine Systems - www.amphenol-sine.com	
2) PL DEC ±0.15 Angles ±1°		44724 Morley Drive	
3) Note reference =		Clinton Township, MI 48036	
MATERIAL SPECIFICATIONS:		CUSTOMER:	
PROCESS SPECIFICATIONS:		THIS DRAWING IS SUPPLIED FOR INFORMATION ONLY. DESIGN FEATURES, SPECIFICATIONS AND PERFORMANCE DATA SHOWN HEREON ARE THE PROPERTY OF THE AMPHENOL CORPORATION. NO RIGHTS OF REPRODUCTION ARE IMPLIED. ALL DIMENSIONS ARE SUBJECT TO NORMAL MANUFACTURING VARIATIONS.	
NEXT ASSY:		SCALE: NONE	
		SIZE: B	REVISION: A2
		TYPE: C-	DWG NO: RTS710*6P*
		ECO-MATE, RECEPTACLE, JAM NUT, SIZE 10,6POS,PIN.	
		SHEET 1 OF 1	

TITLE: ECO-MATE RECEPTACLE JAM NUT SIZE 10,6POS,PIN

DWG NO:

RTS710*6P*

REV: A2

SH: 1

OF: 1