

**SENCITY® Rail MIMO Antenna with GNSS/LNA**

1399.99.0130

**Properties**

- Railway rooftop antenna for 2G/3G/4G/5G cellular and Wi-Fi 6E bands
- Rugged design, meets EN 50155 Railway Standard
- Fire retardant according to EN 45545-2
- Embedded GNSS antenna with integrated LNA supports GPS L1, Galileo E1, BeiDou B1 and GLONASS G1
- Dedicated grounding contact and Cable conduit support (sold separately)



Electrical bands				
	Band 1	Band 2	Band 3	Band 4
Name				
Frequency (MHz)	617 MHz ... 694 MHz	694 MHz ... 790 MHz	790 MHz ... 960 MHz	1350 MHz ... 2700 MHz
Impedance	50 Ω	50 Ω	50 Ω	50 Ω
VSWR	1.7	1.7	1.7	1.8
Gain (dBi)	6 dBi	5 dBi	6 dBi	7.5 dBi
Isolation between Ports	15 dB	15 dB	15 dB	20 dB
Ambient Temperature	25 °C	25 °C	25 °C	25 °C
Composite Power max	80 W	80 W	80 W	80 W

	Band 5	Band 6	Band 7	Band 8
Name				GNSS
Frequency (MHz)	2700 MHz ... 3300 MHz	3300 MHz ... 4900 MHz	4900 MHz ... 7125 MHz	1559 MHz ... 1610 MHz
Impedance	50 Ω	50 Ω	50 Ω	50 Ω
VSWR	2	2.1	1.9	1.8
Gain (dBi)	6.5 dBi	6.5 dBi	7.5 dBi	
Isolation between Ports	25 dB	25 dB	35 dB	
Ambient Temperature	25 °C	25 °C	25 °C	25 °C
Composite Power max	80 W	80 W	80 W	

**SENCITY® Rail MIMO Antenna with GNSS/LNA**

1399.99.0130

**Electrical remarks**

Remarks	<p>Indicated VSWR values are valid for a metallic ground plane of 0.5 x 0.5m or larger. In the 790-7125 MHz band, Indicated VSWR values are also valid for installations on non-metallic surfaces (no specific ground plane requirements). Indicated gain values will be achieved on a metallic ground plane of 1 x 1 m or larger.</p> <p>High-voltage-protection: no voltage on RF port, if the catenary line touches antenna (EN 50124-1, 27.5 kVAC/1min). High-current-protection: Designed acc. to UIC 533, DC-grounded antenna element protection against lightning and short circuit with catenary lines (EN50388, EN 50122-1, 40kA/0.1sec)</p>
---------	---

**Ports**

	Port 1	Port 2	Port 3	Port 4
Port name	Cell/WiFi 1	Cell/WiFi 2	GNSS	GNSS
Connector	N, jack (female)	N, jack (female)	TNC, plug (male)	
Cable type	RADOX_RF_142	RADOX_RF_142	RADOX_RF_316_D	
Cable length	0.24 m	0.12 m	0.17 m	
Polarization	vertical	vertical	circular right	
DC grounded	Yes	Yes	No	

**Connections**

Port number	Port 1	Port 2	Port 3
Band 1	✓	✓	
Band 2	✓	✓	
Band 3	✓	✓	
Band 4	✓	✓	
Band 5	✓	✓	
Band 6	✓	✓	
Band 7	✓	✓	
Band 8			✓

**Mechanical data**

Weight	1.5 kg
Dimensions	81.6 mm x 102.5 mm x 352.5 mm (Height x Width x Depth)
Windload	Wind Speed survival: 500 km/h
Remarks	Mounting: Shall be installed in longitudinal position to the wind/driving direction. Suitable for installation on high speed trains with a maximum speed of 500 km/hr. 4x composite sealing washers included for silicone-free sealing of the mounting screws.

**Interface and material data**

Radome material	ASA (acrylic ester-styrene-acrylonitrile)
Radome colour	RAL 7043 (dark grey)
Back plate/base plate material	Aluminium
Back plate/base plate plating	Passivated (Plating)
Back plate/base plate colour	Grey
Housing material and surface treatment	Grey

**SENCITY® Rail MIMO Antenna with GNSS/LNA**

1399.99.0130

Environmental data	
Operation temperature	-55 °C ... 85 °C
Storage temperature	-55 °C ... 85 °C
Transport temperature	-55 °C ... 85 °C
Environment (application)	Outdoor
Ingress protection (IP Rating)	IP67, IP69
Flammability rating	EN 45545-2
Solar radiation	DIN 75220
Standards	Railway EN 50155 Railway EN 45545

**Environmental remarks**  
 Environmental tests: EN 50155:2018-05 Flammability rating: EN 45545-2.  
 Corrosion: Low corrosion design according to MIL-F-14072(E), 96 hours Salt Spray test.

**Additional Information**  
 This product meets the Deutsche Bahn specifications for rolling stock equipment. Protected by Patents: DE202015009331(U1), US10116056(B2), CN106663861B.

**Outline drawing**

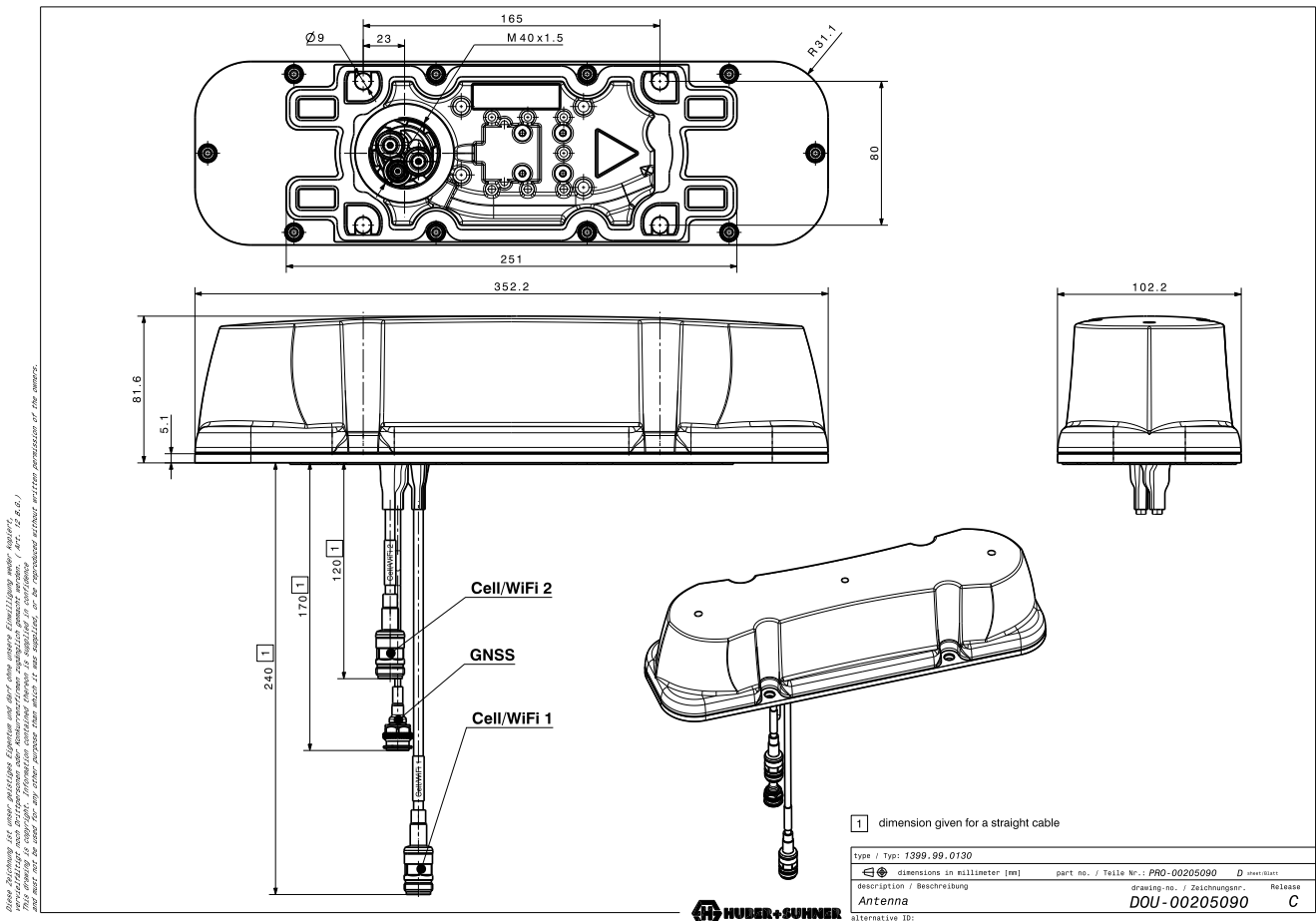

**SENCITY® Rail MIMO Antenna with GNSS/LNA**

1399.99.0130

HUBER+SUHNER is certified by ISO 9001, ISO 14001, ISO 45001, IATF 16949, AS/EN 9100 and ISO/TS 22163-IRIS. Waiver: Facts and figures herein are for information only and do not represent any warranty of any kind.  
DOCUMENT PIM-P3209 / Date of publication: 07.02.2024 / uncontrolled copy