



VG VuG9 250A (120V)

M44-D3-1



DATA SHEET

release. b - Revision 03-2019

Voltage	Frequency	Input Power	Input Current	Airflow	Rotation speed	Direction rotation	Admissible Temperature
V	Hz	W	A	m ³ /h	RPM		Min/Max
120	50/60	147	1,95	1870	2615	R	-25°C / +60°C
120	50/60			1100 CFM			-13°F / 140°F

ErP 2013 OK ErP 2015 OK

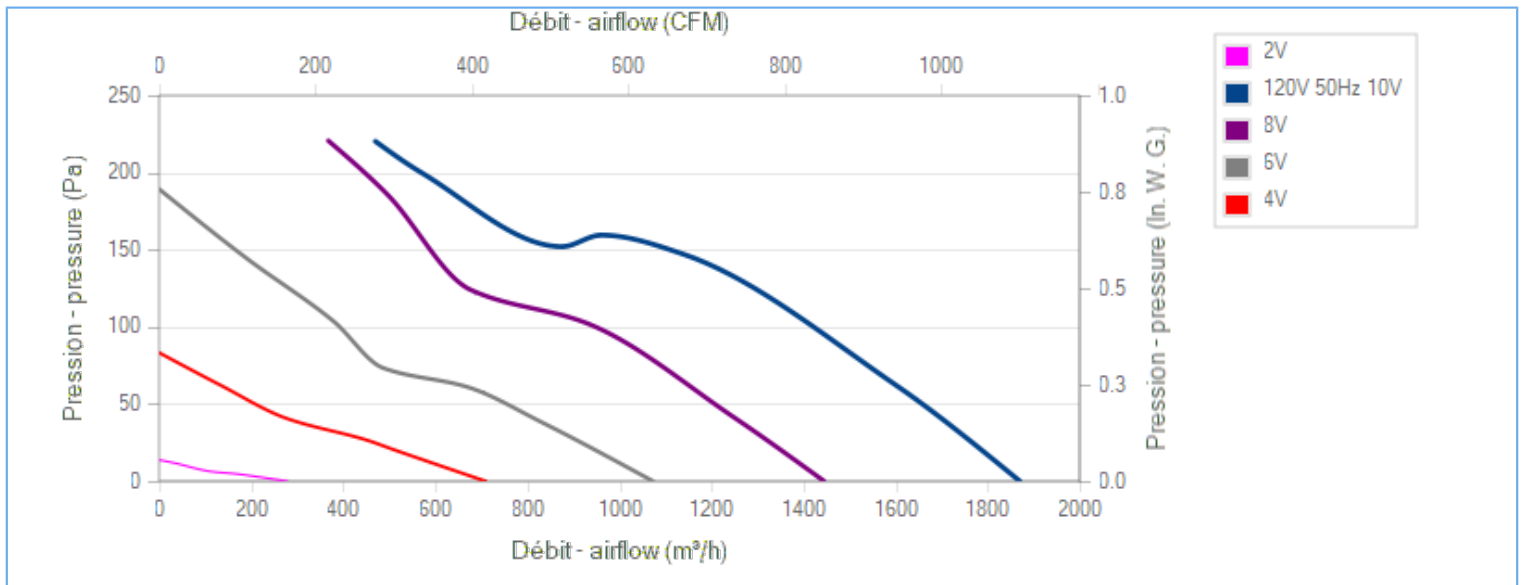
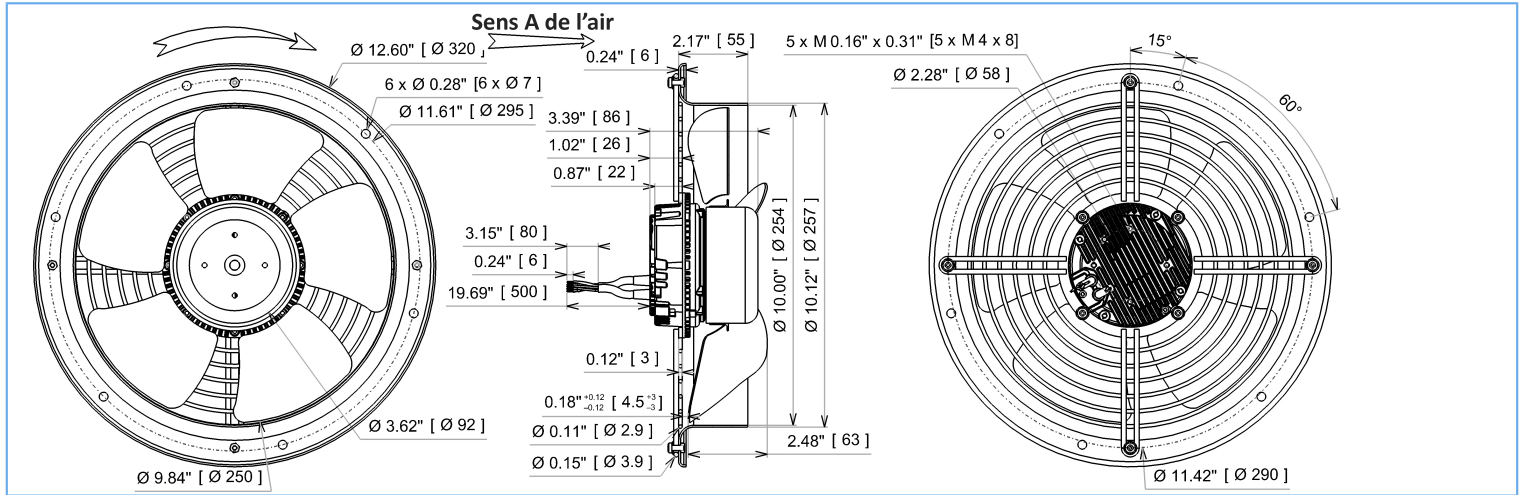
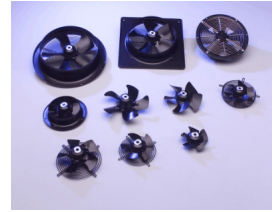

Description

- .Weight : 1,9 Kg
- .Ball bearing
- .Insulation Class F
- .IP4x may be IP44 according to EN60034-5 after checking the integration into the customer appliance
- .G6.3 balancing
- .Rotor and impeller : black paint
- .Finger guard and ring : black paint
- .Motor - UL Recognized component

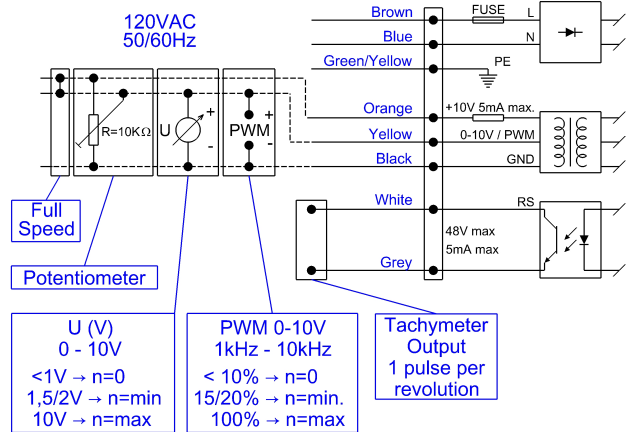

Non contractual document. All specifications are subject to change without prior notice. Picture for information only.



VG VuG9 250A (120V)

M44-D3-1



DATA SHEET

release. b - Revision 03-2019

Data in accordance to ErP directive

Voltage	120	V
Frequency	50	Hz
Power	0,150	kW ⁽¹⁾
Airflow	1138	m ³ /h ⁽¹⁾
Pressure	147	Pa ⁽¹⁾
Rotation speed	2421	RPM ⁽¹⁾

(1) at optimal efficiency point

	Actual	Request 2013	Request 2015
Overall efficiency (η)	35,2	24,5	28,5
Efficiency grade	47	36	40
Installation category	A		
Efficiency category	static		
Variable speed drive	Yes		
Specific ratio	1,00		

Designed for regular application according ErP directive EU 2009/125/EC

Accessories

Measurement setup

16085 VIROLE V250 RONDE

Documents

Manuel d'utilisation

www.ecofit.com/site/normes

Operating and recycling manual

www.ecofit.com/anglais/normes

UL1004-1, 2nd edition "rotating electrical machine"
 UL1004-3, 1st edition "thermally protected motors"
 UL1004-7, 2nd edition "electronically protected motors"
 C22.2 N°100-04, 6th edition "motors and generator"
 C22.2 N°77-95, 7th edition "motors with inherent overheating protection"
 UL Motor Model : RT9191
 File Number : E326930 XDNW2,8

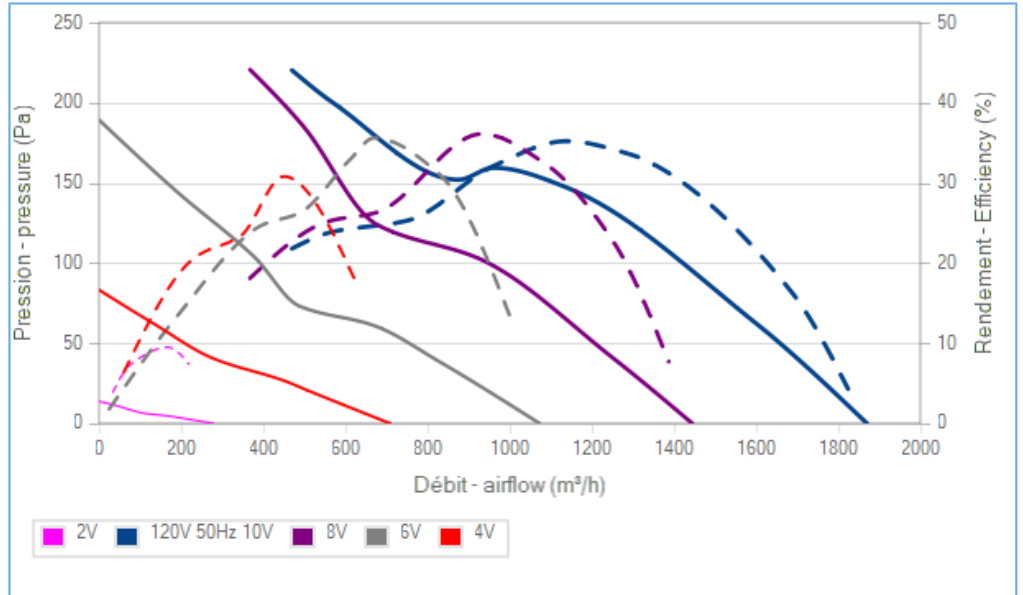
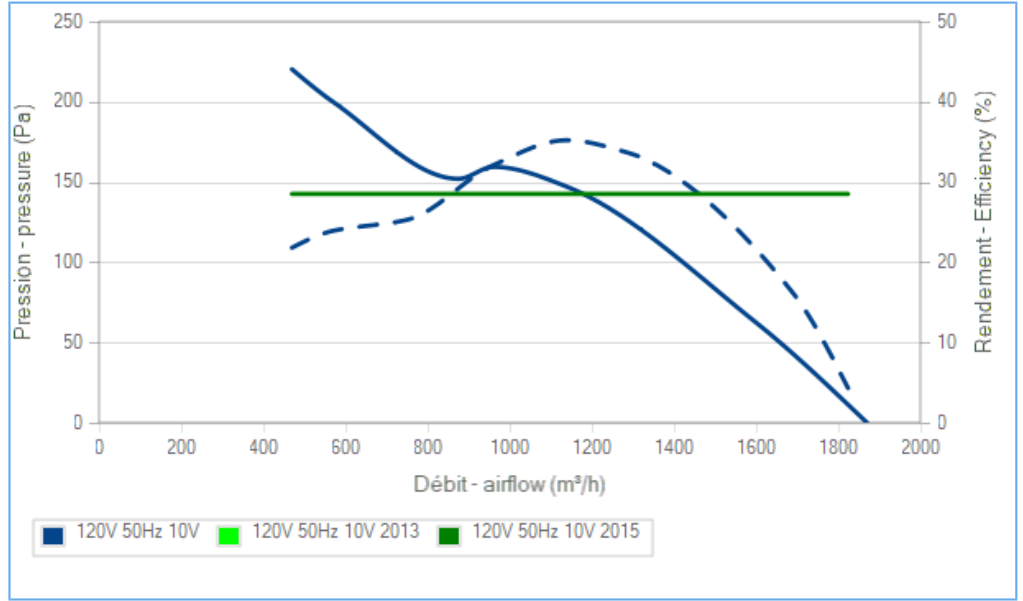

La courbe de rendement intègre le facteur de compensation de charge partielle du règlement (UE) n°327/2011
 The efficiency curve includes part load compensation factor of regulation (EU) n°327/2011

Non contractual document. All specifications are subject to change without prior notice. Picture for information only.