



2GREuA3 120x62R

P45-A2



DATA SHEET

release. a - Revision 01-2018

Voltage	Frequency	Input Power	Input Current	Capacitor	Airflow	Rotation speed	Acoustic level	Direction rotation	Admissible Temperature
V	Hz	W	A	µF	m³/h	RPM	dBA	↻	Min/Max
230	50	58	0,27	2,0	260	1715	55	R	-40°C / +70°C
230	60	67	0,32	2,0	250	1635	54	R	-40°C / +70°C
230	50				153 CFM				-40°F / 158°F
230	60				147 CFM				-40°F / 158°F



dBA : free blowing

NA : not applicable

ErP 2013

NA

ErP 2015

NA

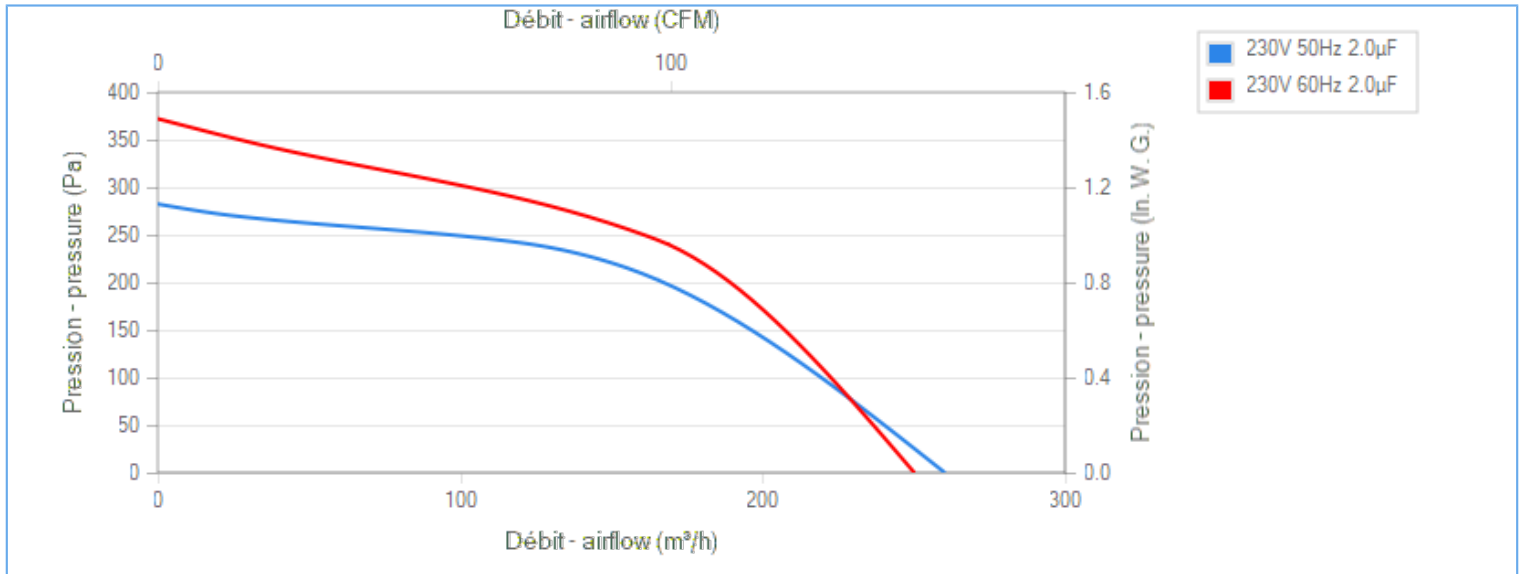
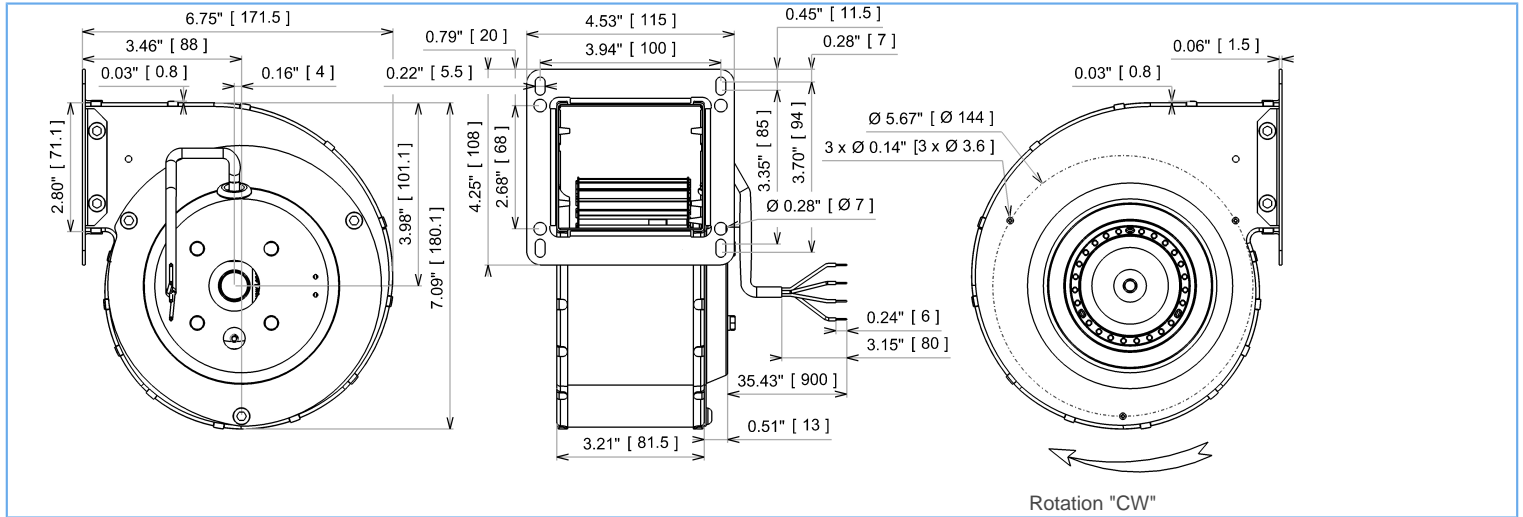

Tested with ECOFIT housing

Description

- .Weight : 1,8 Kg
- .Ball bearing
- .Class F, thermally protected
- .IP44 protection depending on installation and position as per EN60034-5
- .G2.5 balancing
- .Galvanized steel impeller
- .Rotor : black paint
- .Motor - UL Recognized component

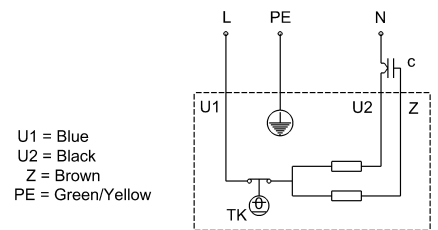



2GREuA3 120x62R

P45-A2



DATA SHEET

release. a - Revision 01-2018

Data in accordance to ErP directive

Voltage	230	V
Frequency	50	Hz
Power	0,049	kW ⁽¹⁾
Airflow	155	m ³ /h ⁽¹⁾
Pressure	215,3	Pa ⁽¹⁾
Rotation speed	2394	RPM ⁽¹⁾

(1) at optimal efficiency point

ErP directive (EU 2009/125/EC) not applicable :
Power at optimum energy efficiency point

Accessories

- 19217
- 19217
- 21236

Measurement setup

16104 OUIE OS96 TOLE XC

Documents

- Manuel d'utilisation
www.ecofit.com/site/normes
- Operating and recycling manual
www.ecofit.com/anglais/normes



UL2111 (XEW2,8)
N° file E135223
2RS73



A041865
2RS73CN

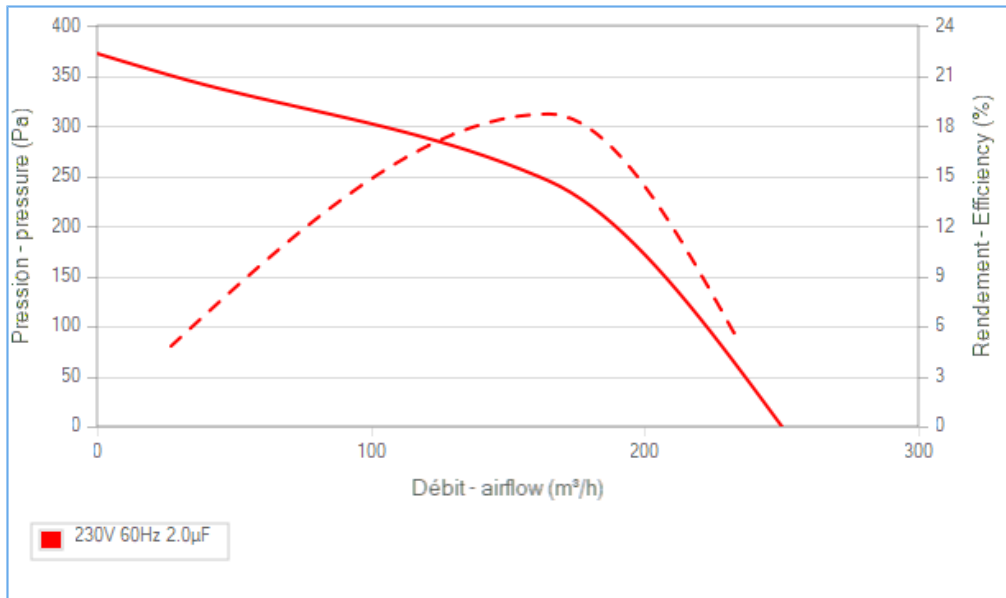
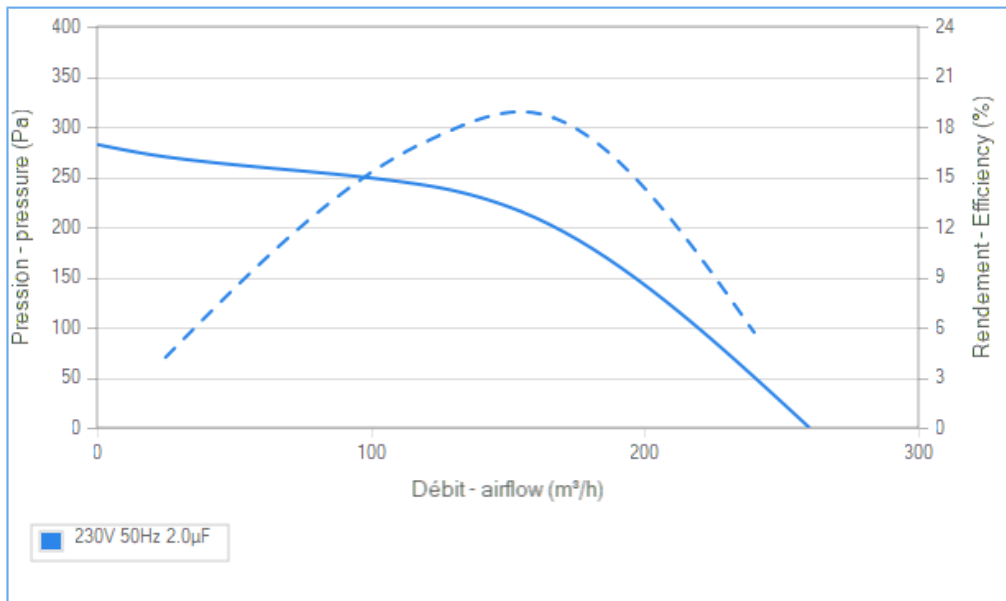

Non contractual document. All specifications are subject to change without prior notice. Picture for information only.