

## A5-(S)DE-J098R26

High SNR / Multiple Clock Mode  
/ Narrow Sensitivity

OMNI-DIRECTIONAL  
BOTTOM PORT

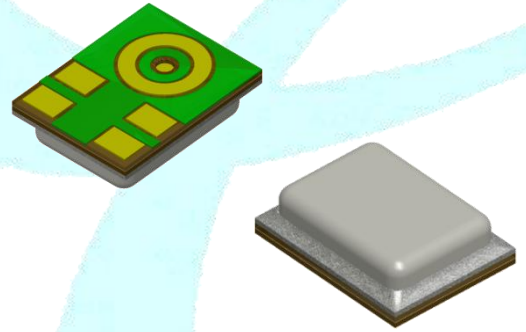

### Best sound electronics

Value no1. Micro sound provider

Creative technology starts from respecting of life  
of the individuals

Creative technologies to respect human life

### Best sound electronics

Value no1. Micro sound provider

We offer you happiness with our excellent technology  
beyond an ordinary sound what you expect

Superior technology to deliver happiness

### Best sound electronics

Value no1. Micro sound provider

Keep basic fundamentals to fill sound with  
new innovations

Creative technologies to respect human life

## INDEX

1. INTRODUCTION
2. APPLICATIONS
3. MODEL NO.
4. ABSOLUTE MAXIMUM RATINGS
5. GENERAL MICROPHONE SPECIFICATIONS
6. ELECTRO-ACOUSTIC CHARACTERISTICS
7. INTERFACE PARAMETER
8. MEASUREMENT CIRCUIT
9. PIN DESCRIPTION
10. INTERFACE CIRCUIT & CHANNEL DATA CONFIGURATION
11. INTERFACE TIMING CHART
12. ENVIRONMENTAL CHARACTERISTICS AND STANDARD CONDITIONS
13. TYPICAL FREQUENCY RESPONSE CURVE
14. MECHANICAL CHARACTERISTICS
15. RELIABILITY TEST CONDITIONS
16. PACKAGING SPECIFICATION
17. MEASUREMENT SYSTEM
18. SOLDER REFLOW PROFILE
19. RECOMMENDED PICK UP NOZZLE CONDITIONS
20. APPLICATION EXAMPLE
21. HANDLING GUIDE
22. REWORK

## 1. INTRODUCTION

- Digital MEMS Microphone - ½ Cycle PDM 1bit, Full Scale=120dBSPL
- Bottom Port Type – Sensitivity is Typical -26dBFS at LPM and STM
- **High Signal to Noise Ratio(SNR) – Typical 64.0dB (A-weighted, 20Hz~20kHz) at fclk=2.4MHz**
- **Multiple Clock Mode – Stand by Mode, Low-Power Mode(LPM), Standard Mode(STM)**
- **Narrow Sensitivity – +/-1dB**
- Omni-directional
- Dual Channel supported
- RF Shielded – with embedded Capacitor
- Compatible with Sn/Pb and Halogen-free solder process
- RoHS compliant
- SMD reflow temperature of up to 260°C for over 30 seconds

## 2. APPLICATIONS

- Smartphones
- Ear-sets, Bluetooth Headsets
- Smart Speaker, Set Top Box
- Remote Controller
- Tablet Computers
- Wearable Devices
- Electrical Appliances
- Voice Recognition Systems of Appliances

## 3. MODEL NO.

**A5-(S)DE-J098R26**

## 4. ABSOLUTE MAXIMUM RATINGS

Parameter	Absolute maximum rating	Units
Vdd to Ground	3.6	V
Digital Input & Output to Ground	Vdd+0.3	V
Input Current	5	mA
Short Circuit Current to/from Data	Infinite to Ground or Vdd	sec

Caution : Stresses above those listed in “Absolute maximum ratings” may cause permanent damage to the device.

These are stress ratings only. Functional operation at these or any other conditions beyond those indicated under “ELECTRO-ACOUSTIC CHARACTERISTICS” is not implied. Exposure beyond those indicated under “ELECTRO-ACOUSTIC CHARACTERISTICS” for extended periods may affect device reliability.

## 5. GENERAL MICROPHONE SPECIFICATIONS

Test Condition : 23 ± 2°C, Room Humidity = 55 ± 20 %, Vdd=1.8V, fclk = 2.4MHz, SELECT Pin is grounded, CLOAD = 1µF, unless otherwise noticed

Parameter	Conditions	Min	Typ	Max	Units	
* Clock Frequency Range	Standby Mode	fCLK	150		310	Hz
	Low-Power Mode	fCLK	380		980	kHz
	Standard Mode	fCLK	1.17		3.1	MHz
Standby mode Current	fCLK = 250Hz		25		µA	
Short Circuit Current	Grounded DATA pin	1	-	20	mA	
Vdd Ramp-up Time (Power-up)	Vdd ≥ Vdd (min)	-	-	50	ms	
Startup Time	Time to start up in any mode after VDD and CLOCK applied	-	-	50	ms	
Reset Time	Time to start up in any mode after VDD has been off for more than 10ms, while CLOCK remained on	-	-	50	ms	
Mode-Change Time	Time to switch between modes. VDD remains on during the mode switch	-	-	50	ms	

\* Note : Must be consulted when used another clock frequency without the typical clock frequencies.

## 6. ELECTRO-ACOUSTIC CHARACTERISTICS

Test Condition : 23 ± 2°C, Room Humidity = 55 ± 20 %, Vdd=1.8V, fclk = 2.4MHz, SELECT Pin is grounded, CLOAD = 1μF, unless otherwise noticed

Parameter	Conditions	Min	Typ	Max	Units
Directivity		Omni-directional			
Supply Voltage (Vdd)		1.62	-	3.6	V
Sensitivity Change across Voltage	Vdd=1.62~3.6V, fclk=3.072MHz	No change			dB
Data Format		½ Cycle PDM 1bit			-
Full Scale Acoustic Level		120			dB SPL
Current Consumption (Idd)	fclk = 0.768kHz, no load on DATA output		125		μA
	fclk = 2.4MHz, no load on DATA output		555		
	fclk = 3.072MHz, no load on DATA output		580		

### ● Standard Mode

Test Conditions : Measurement Clock Frequency=2.4MHz, Vdd=1.8V

Current consumption (Idd)	No load on DATA output		555		μA
Sensitivity	94dB SPL at 1kHz	-27	-26	-25	dBFS
Signal to Noise Ratio (SNR)	94dB SPL at 1kHz, A-weighted (20Hz~20kHz)	-	64	-	dB(A)
Total Harmonic Distortion (THD)	94dB SPL at 1kHz	-	0.2	-	%
	100dB SPL at 1kHz	-	1	-	%
	120dB SPL at 1kHz	-	10	-	%
Acoustic Overload Point (AOP)	THD>10%, at 1kHz		120	-	dB SPL
Power Supply Rejection Ratio (PSRR)	Measured with 1kHz sine wave and broad band noise, both 200mVpp	-	50	-	dBV/FS
Power Supply Rejection (PSR)	Measured with 217Hz square wave and broad band noise, both 100mVpp, A-weighted	-	-81	-	dBFS(A)

### ● Low Power Mode

Test Conditions : Measurement Clock Frequency=768kHz, Vdd=1.8V

Current consumption (Idd)	No load on DATA output	-	125	-	μA
Sensitivity	94dB SPL at 1kHz	-27	-26	-25	dBFS
Signal to Noise Ratio (SNR)	94dB SPL at 1kHz, A-weighted (20Hz~8kHz)	-	64	-	dB(A)
Total Harmonic Distortion (THD)	94dB SPL at 1kHz	-	0.2	-	%
	100dB SPL at 1kHz	-	1	-	%
	120dB SPL at 1kHz	-	10	-	%
Acoustic Overload Point (AOP)	THD>10%, at 1kHz		120	-	dB SPL
Power Supply Rejection Ratio (PSRR)	Measured with 1kHz sine wave and broad band noise, both 200mVpp	-	51	-	dBV/FS
Power Supply Rejection (PSR)	Measured with 217Hz square wave and broad band noise, both 100mVpp, A-weighted	-	-82	-	dBFS(A)

## 7. INTERFACE PARAMETER

Parameter	Conditions	Min	Typ	Max	Units
Clock Duty Cycle		40	50	60	%
Input Logic Low Level		-0.3	-	0.35 x Vdd	V
Input Logic High Level		0.65 x Vdd	-	Vdd + 0.3	V
Output Load Capacitance on DATA		-	-	200	pF
Clock Rise / Fall Time		-	-	10	ns
Time required for data valid on the rising edge clock (Tdvr)	RL=1MΩ, CL=12pF	18	-	40	ns
Time required for data valid on the falling edge clock (Tdvf)	RL=1MΩ, CL=12pF	18	-	40	ns
Time required for data to be Z (Tdz)	RL=1MΩ, CL=12pF	0	-	15	ns

**8. MEASUREMENT CIRCUIT**

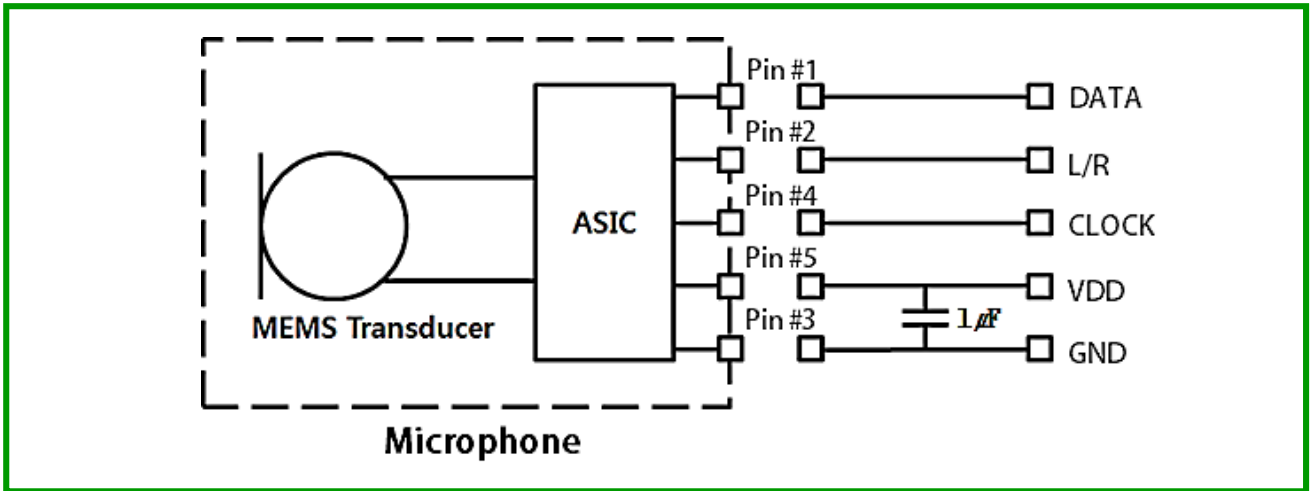

**9. PIN DESCRIPTION**

Pin Name	Description
Vdd	Supply and IO voltage for the microphone
L/R Select	Left/Right ( DATA2 / DATA1 ) Channel selection
CLOCK	Clock input to the microphone
DATA	PDM data output from the microphone
GND	Ground

**10. INTERFACE CIRCUIT & CHANNEL DATA CONFIGURATION**

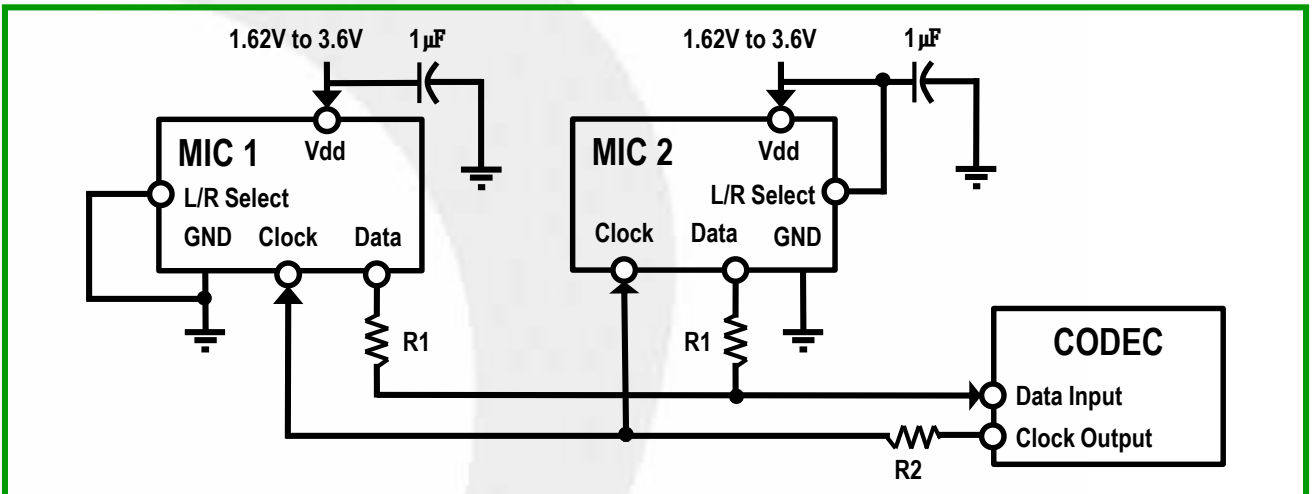

Data symbol in interface timing chart	L/R Select connected to	Data asserted at	Data sampled at
DATA1 [MIC1(Low)]	GND	Falling clock edge	Rising clock edge
DATA2 [MIC2(High)]	Vdd	Rising clock edge	Falling clock edge

Note 1 : Stereo operation is accomplished by connecting the L/R Sel. pin either to Vdd or GND on the phone PWB.

Bypass Capacitors near each MIC. on Vdd are recommended to provide maximum SNR performance.

Note 2 : R1(Data source termination Resister) should be as close as possible to each the MIC. (50Ω~100Ω)

Note 3 : R2(Clock source termination Resister) should be as close as possible to the CODEC. (50Ω~100Ω)

**11. INTERFACE TIMING CHART**

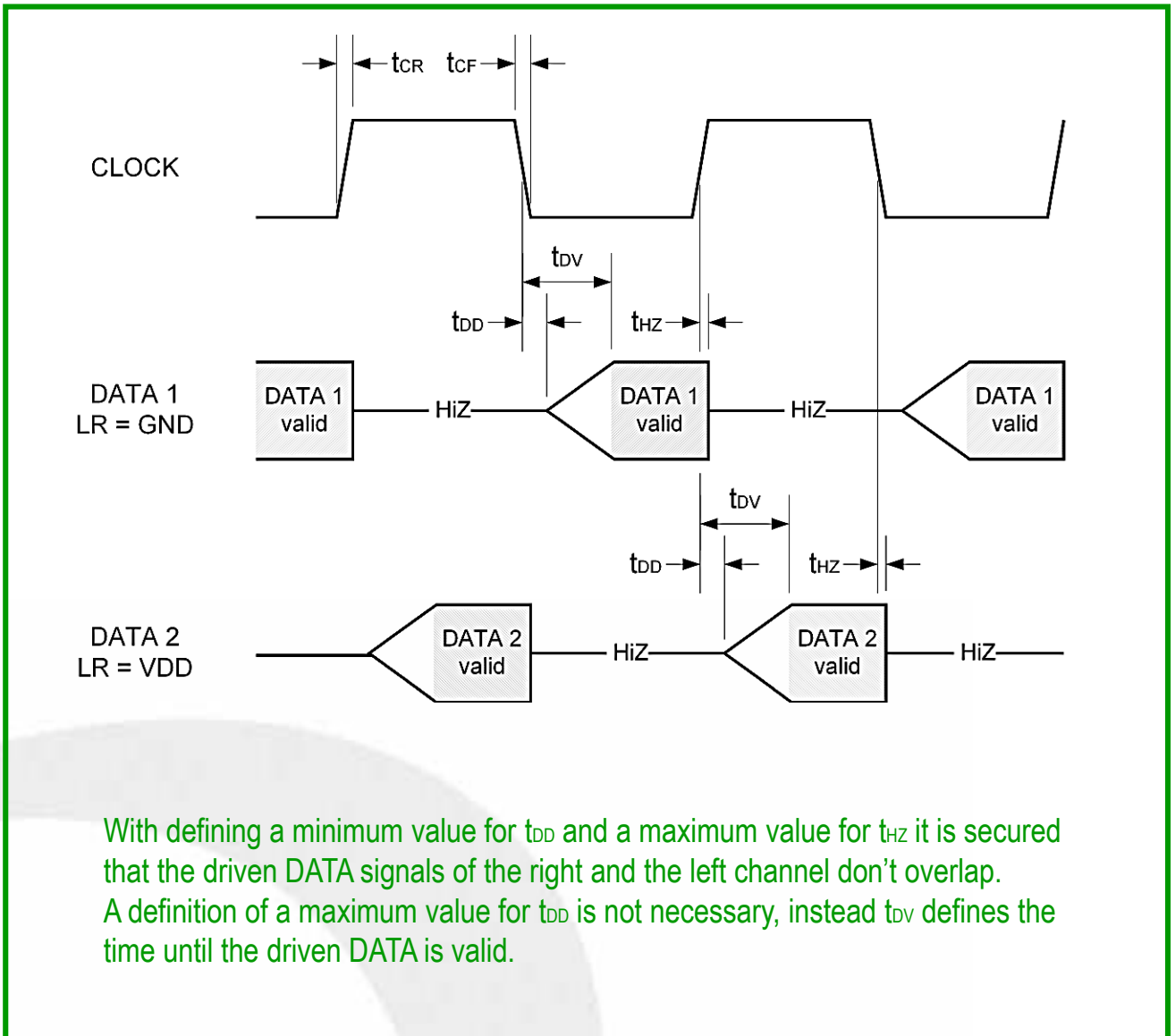

**12. ENVIRONMENTAL CHARACTERISTICS AND STANDARD CONDITIONS**

Item	Min	Typ	Max	Unit
Operating temperature range	-40	-	+100	°C
Storage temperature range	-40	-	+100	°C
Relative humidity	25	-	85	%
Air Pressure	860	-	1060	mBar
Standard temperature range	15	20	25	°C
Standard Relative humidity	40	-	60	%



### 13. TYPICAL FREQUENCY RESPONSE CURVE

**Far Field Measurement Condition**

Temperature : 23 ± 2 °C

Supply Voltage : 1.8V

Clock Frequency : 2.4MHz

Acoustic stimulus : 1Pa ( 94dB SPL at 1kHz ) at 50cm from the loud-speaker.

The loud-speaker must be calibrated to make a flat frequency response input signal.

Position : The frequency response of microphone unit measured at 50cm from the loud-speaker

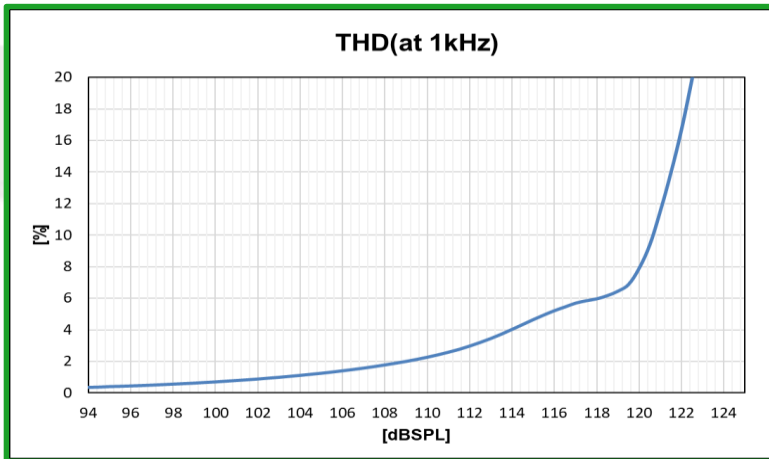
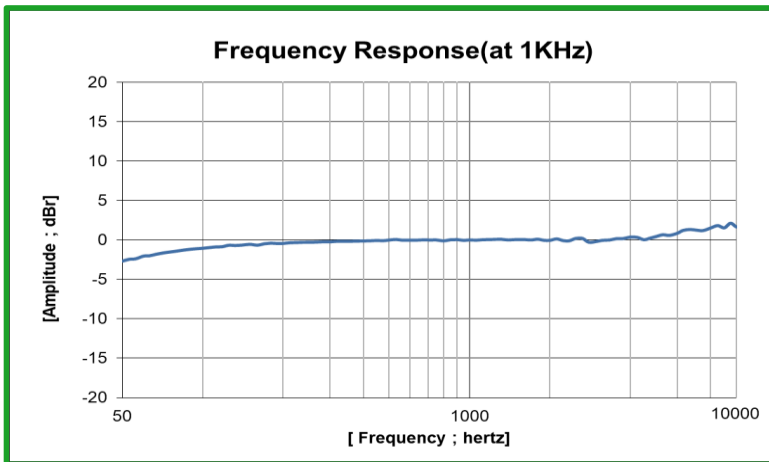

**Frequency Mask Specification**

Frequency [Hz]	Lower Limit [dBr]	Upper Limit [dBr]	Note
50	-4	+2	0dBr = dBFS at 1kHz
100 ~ 1000	-2	+2	
1000	0	0	
1000 ~ 5000	-2	+2	
10000	-2	+5	
15000	-2	+8	

**Note : Band Frequency Range**

- 1. Narrow Band : 300Hz ~ 3.4kHz
- 2. Wide Band : 100Hz ~ 7kHz
- 3. Super Wide Band : 50Hz ~ 14kHz

## 14. MECHANICAL CHARACTERISTICS

※ PCB design & Pin size can be changed by model No.

### SMD Type

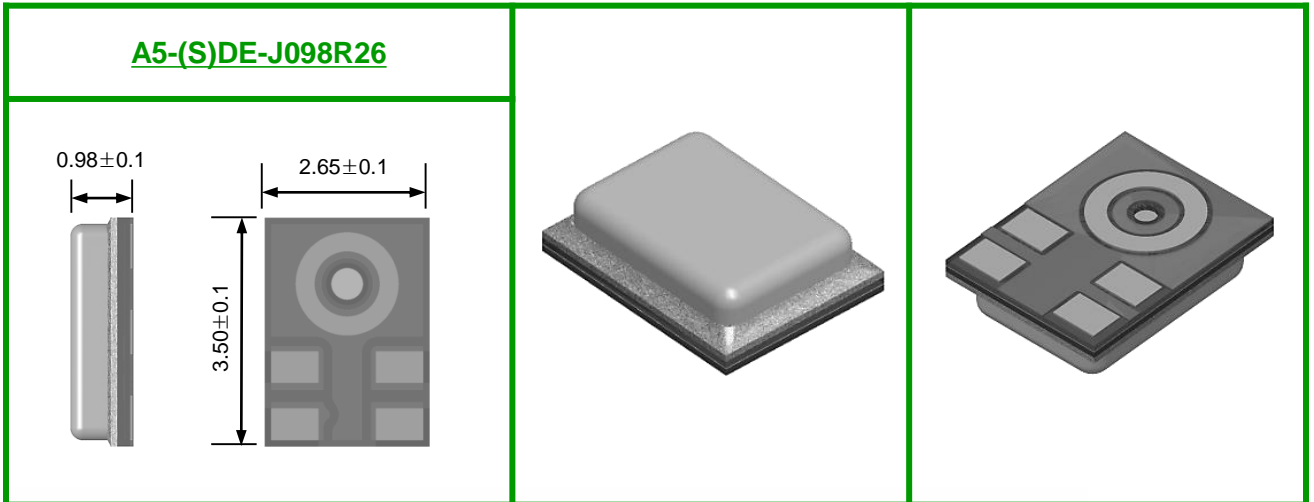

### Lettering

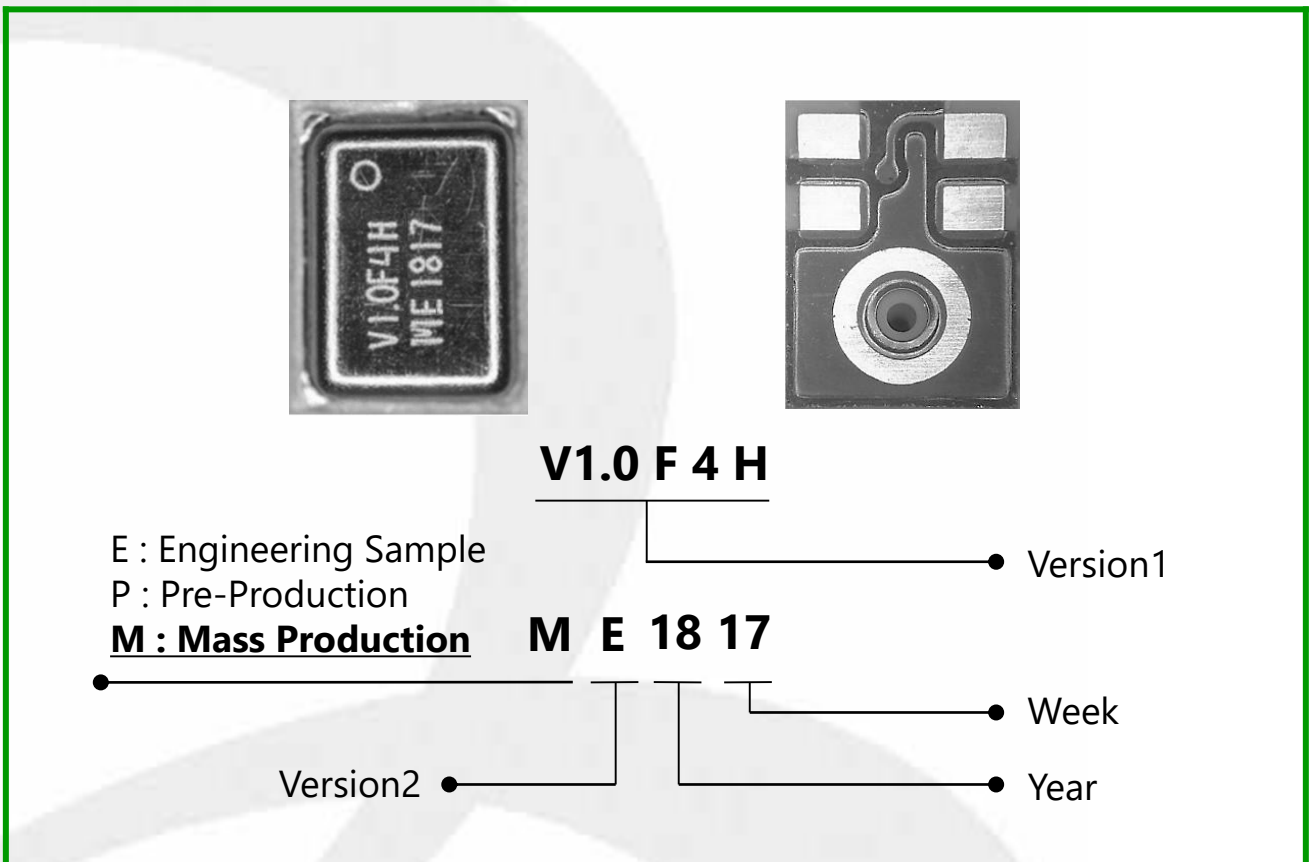

**14. MECHANICAL CHARACTERISTICS**

**- Mechanical dimensions & Pad Lay-out**

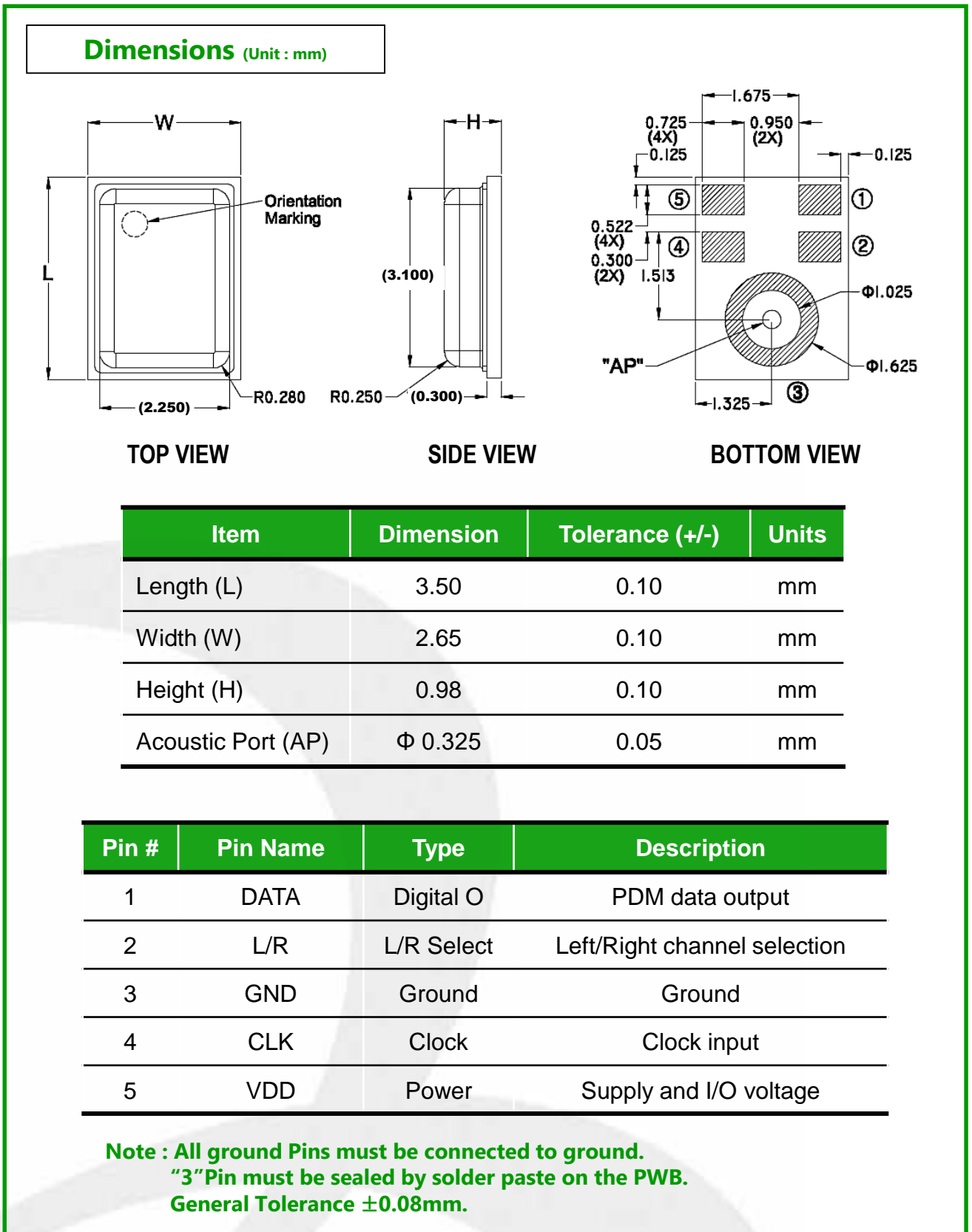

**14. MECHANICAL CHARACTERISTICS**

- Recommended Land Pattern & Stencil Pattern

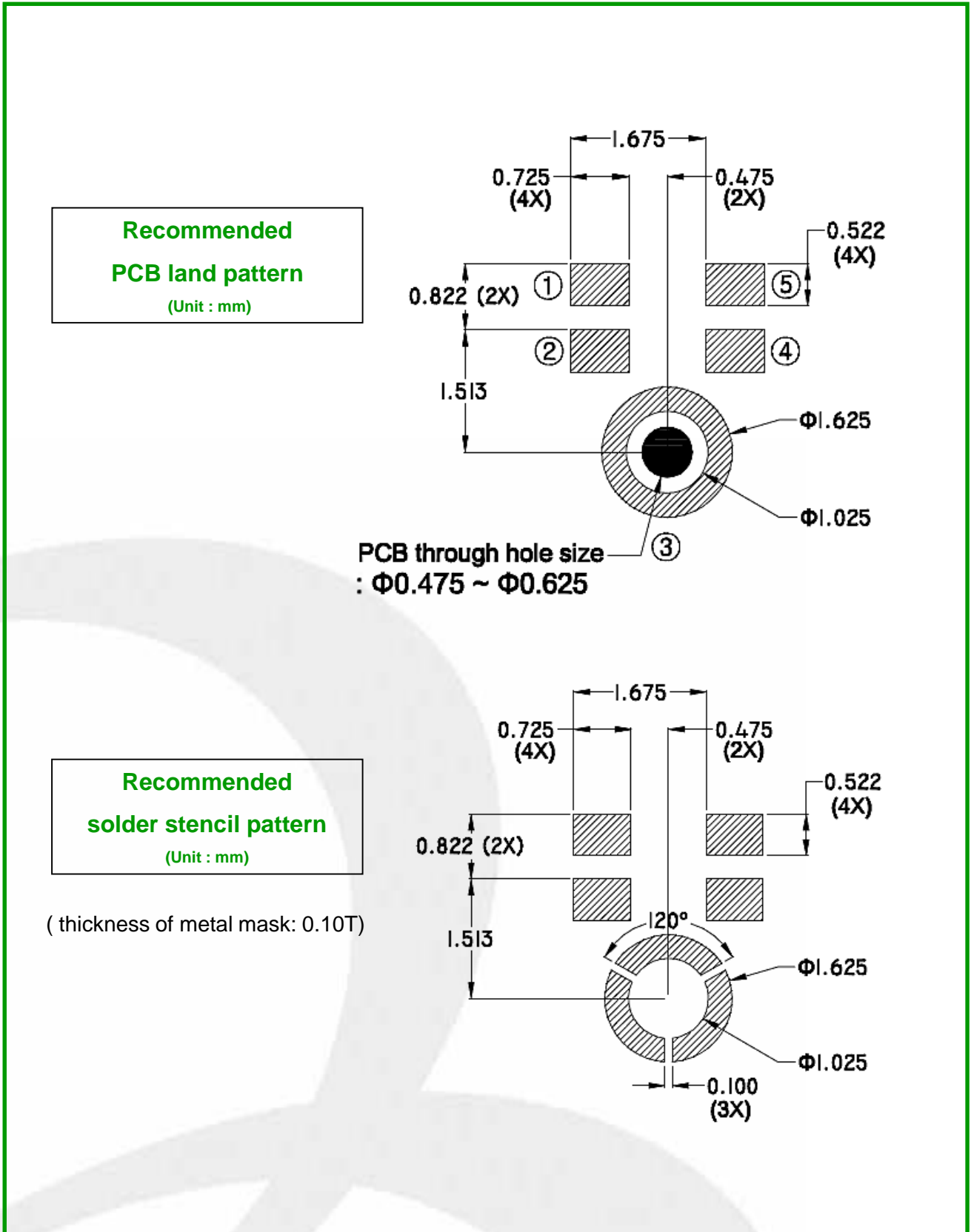

**15. RELIABILITY TEST CONDITIONS**

<b>Note : After test conditions are performed, the sensitivity of the microphone shall not deviate more than <math>\pm 1</math>dB from its initial value.</b>	
<b>TEST</b>	<b>DESCRIPTION</b>
<b>TEMPERATURE STORAGE</b>	[High Temperature Storage] +80°C $\pm$ 3°C x 200hrs (The measurement to be done after 2 hours of conditioning at room temperature)
	[Low Temperature Storage] -30°C $\pm$ 3°C x 200hrs (The measurement to be done after 2 hours of conditioning at room temperature)
<b>TEMPERATURE CYCLE</b>	(-25°C $\pm$ 2°C x 30min -> +20°C $\pm$ 2°C x 10min -> +70°C $\pm$ 2°C x 30min -> +20°C $\pm$ 2°C x 10min) x 5cycles (The measurement to be done after 2 hours of conditioning at room temperature)
<b>THERMAL SHOCK</b>	(+85°C $\pm$ 2°C -> -40°C $\pm$ 2°C Change time : 20sec) x 96cycles Maintain : 30min (The measurement to be done after 2 hours of conditioning at room temperature)
<b>HIGH TEMPERATURE AND HUMIDITY</b>	+85°C $\pm$ 2, 85 $\pm$ %RH, Bias(3.6V) x 200hrs (The measurement to be done after 2 hours of conditioning at room temperature)
	+70°C $\pm$ 2, 95 $\pm$ %RH x 200hrs (The measurement to be done after 2 hours of conditioning at room temperature)
<b>ESD (Electrostatic Discharge)</b>	Air discharge : $\pm 8$ kV, $\pm 10$ kV, $\pm 12$ kV, $\pm 15$ kV Vdd, Data, CLK, L/R, GND Pad each 5 times (Non-ground)
	Contact discharge : $\pm 2$ kV, $\pm 4$ kV, $\pm 6$ kV, $\pm 8$ kV Vdd, Data, CLK, L/R, GND Pad each 5 times (Non-ground)
<b>VIBRATION</b>	Signal 5Hz to 500Hz, acceleration spectral density of 0.01g <sup>2</sup> /Hz in each of 3 axes, 120 min in each axis (360min in total)
<b>DROP</b>	To be no interference in operation after dropped to steel floor 18 times from 1.52 meter height in state of packing
<b>REFLOW SENSITIVITY</b>	5 reflow cycles. Refer to reflow profile from specification item 18.

**16. PACKAGING SPECIFICATION**

- Reel

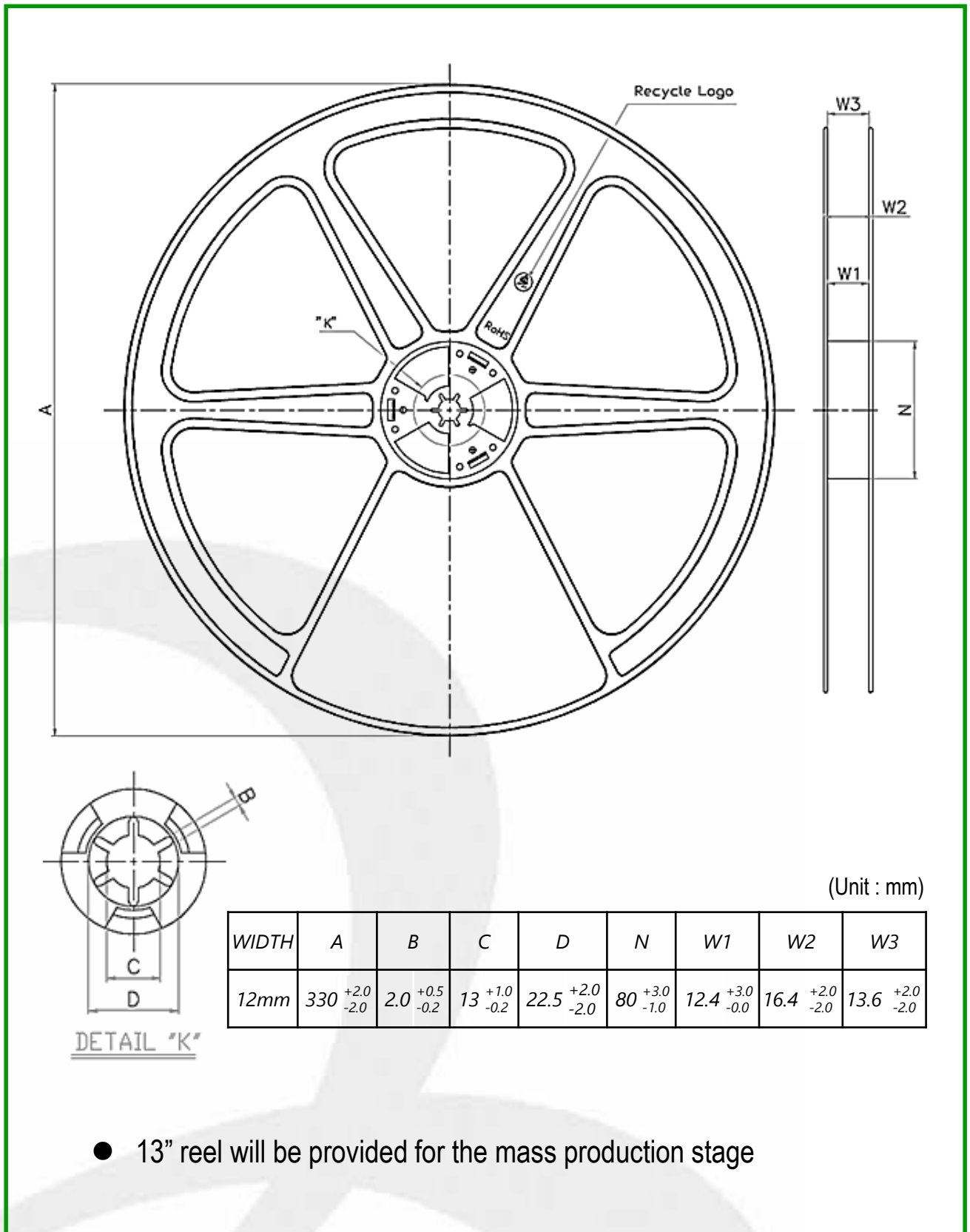

**16. PACKAGING SPECIFICATION**

- Taping

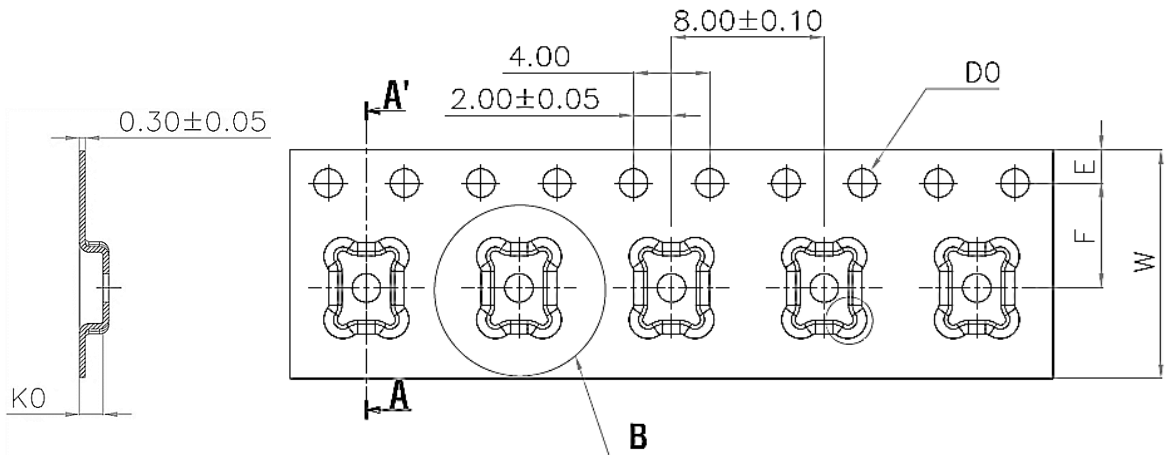

**SECTION A-A'**

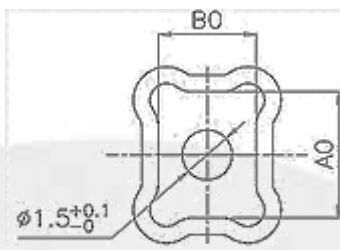

**DETAIL B (2:1)**

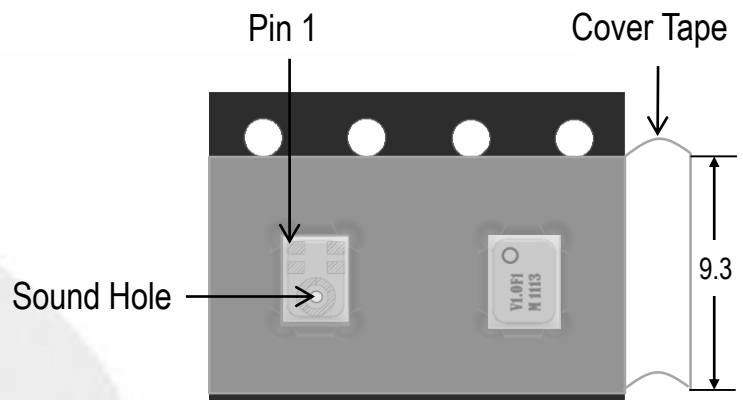

[ Note ]

1. Direction of parts : See above pictures.
2. Microphone total quantity (13" Reel) : 5,000pcs
3. Carrier Tape ESD :  $10^2 \sim 10^{10} \Omega$
4. Cover Tape Inside ESD :  $10^2 \sim 10^{10} \Omega$
5. Carrier Tape Material & Color : PS, Black
6. Thermo Compression Bonding

Unit : mm

A0	3.80±0.10	E	1.75±0.10
B0	2.95±0.10	F	5.50±0.05
K0	1.25±0.10	T	0.30±0.05
D0	1.50±0.10	W	12.00±0.30

**16. PACKAGING SPECIFICATION**

- Packing

**1 Inner Box included 2 reels**  
**→ Microphone total quantity : 10,000 pcs**

[ Note ]  
 1. Inner Box ESD :  $1 \times 10^4 \sim 1 \times 10^{10} \Omega$

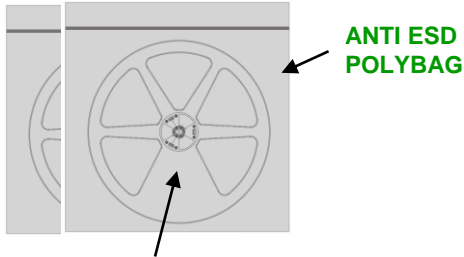

**< 2 Reels >**

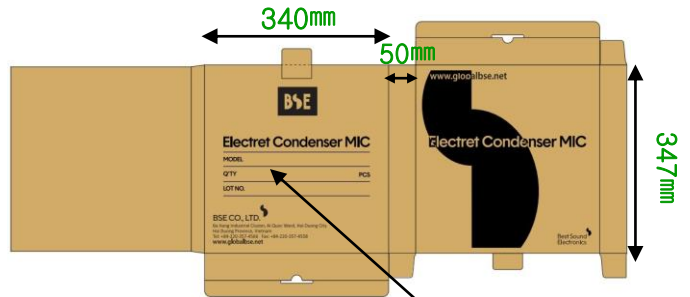

**< Inner Box >**

**2 Outer Box included 5 Inner Boxes**  
**→ Microphone total quantity : 50,000 pcs**

[ Note ]  
 1. Outer Box ESD :  $1 \times 10^4 \sim 1 \times 10^{10} \Omega$

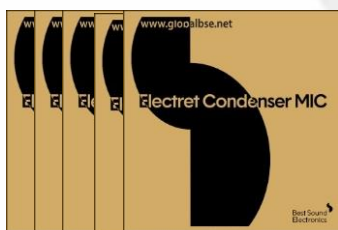

**< 5 Inner Box >**



**< Outer Box >**



**17. MEASUREMENT SYSTEM**

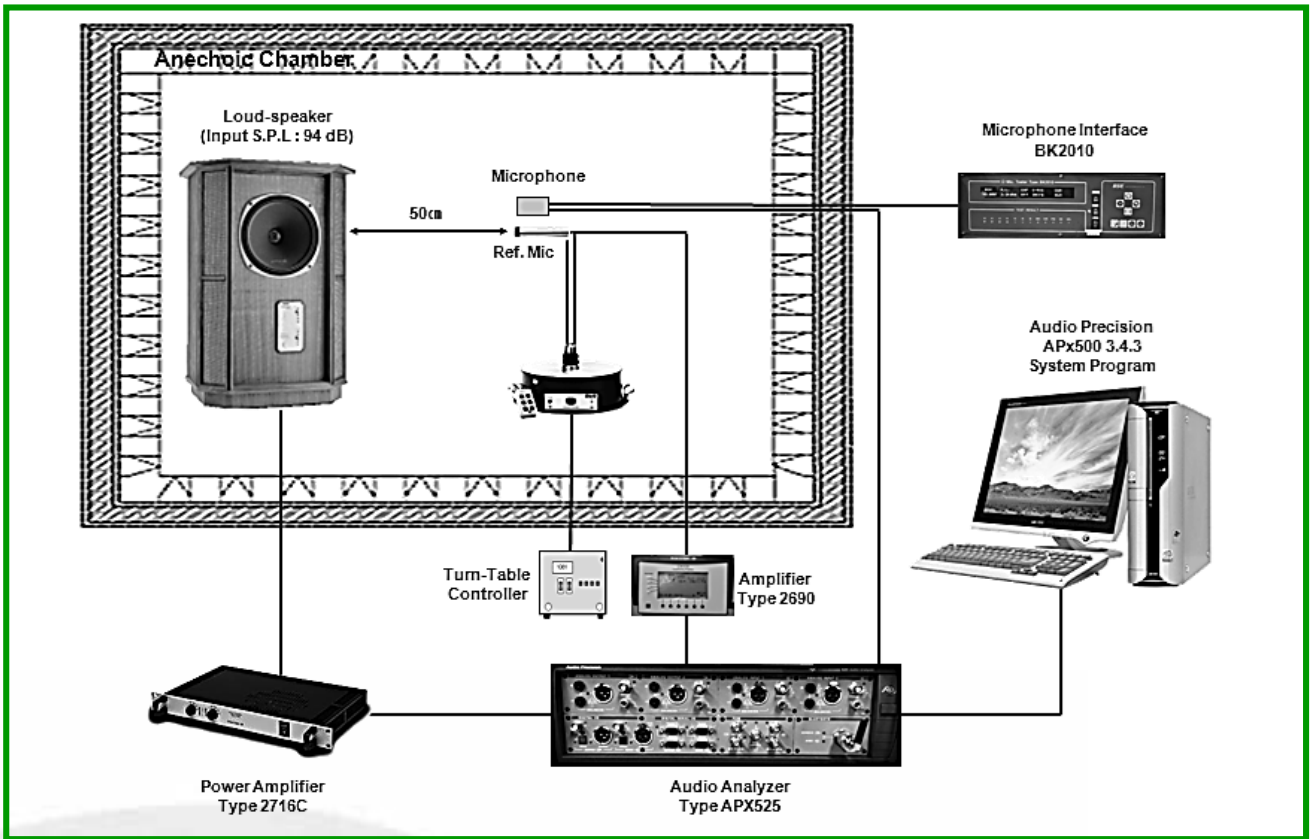

**17.1 Measurement Condition**

- (a) Supply voltage : 2.0V
- (b) Acoustic stimulus : 94dB SPL at 1kHz
- (c) Distance between MIC & SPK : 50cm
- (d) Measurement frequency : 50 (Hz) ~ 20 (kHz)

Machine	Model No	Purpose
Standard MIC	4191	Revision of input signal & SPK spec
Audio Analyzer	APX525	Audio Analysis (include Power Supply)
Loud-speaker	GRF Memory HE	SPK (Input sound Signal occur)
Power Amplifier	2716C	Power amplification
Charging Conditioning Amplifier	2690	Ref. MIC Signal Transformation
Microphone Interface	BK2010	Voltage & impedance supply to MIC
Operating Software	APx500 3.4.4	A-D Freq. Resp.
Sound Level Calibrator	4231	Standard MIC Calibration purpose

**18. SOLDER REFLOW PROFILE**

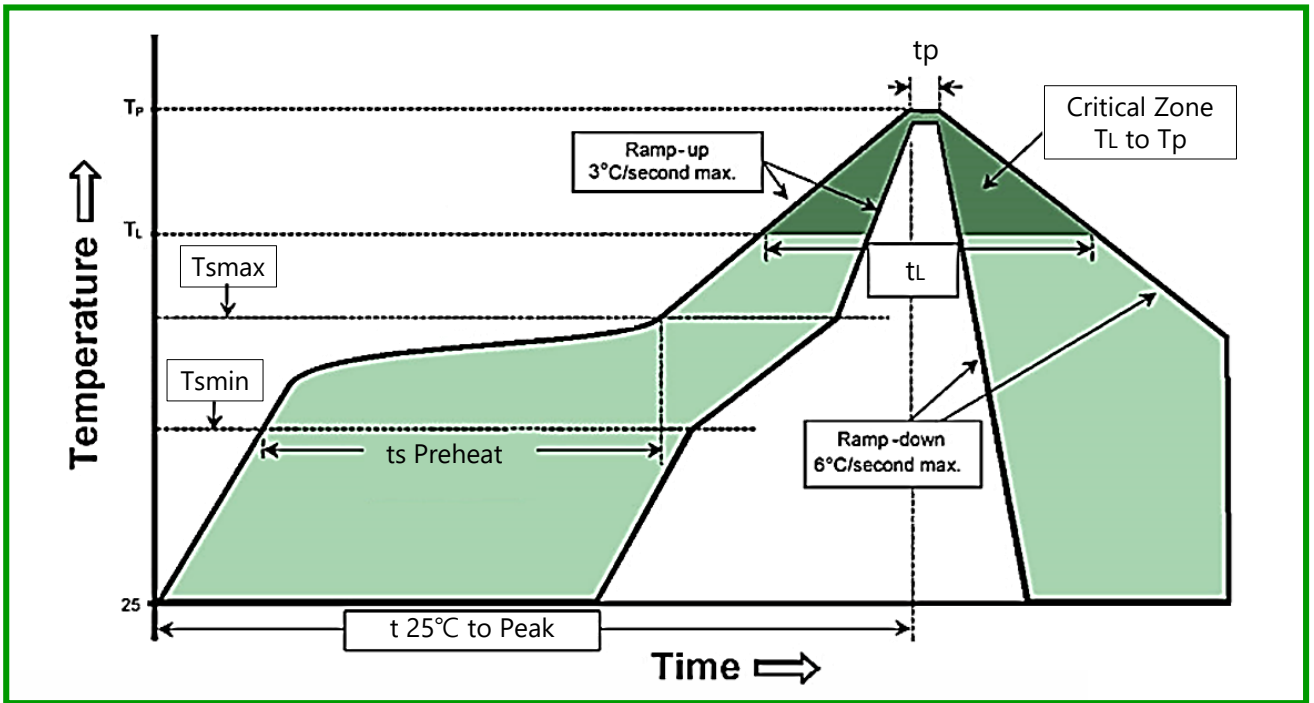

Profile Feature	Pb-Free Assembly
<b>Preheat/Soak</b>	
Temperature Min (Tsmín)	150°C
Temperature Min (Tsmáx)	200°C
Time(ts) from (Tsmín to Tsmáx)	60 ~ 120 seconds
Ramp-up rate (TL to Tp)	3°C/second max.
Liquidous temperature(TL)	217°C
Time(tL) maintained above TL	60 ~ 150 seconds
Peak package body temperature (Tp)	260°C
Time(tp) within 5°C of the specified classification Temperature(Tc)	20 ~ 40 seconds
Ramp-down rate (Tp to TL)	6°C/second max.
Time 25°C to peak temperature	8 minutes max.

**[Notes]**

- Solder Reflow Profile based on [IPC/JDEC J-STD-020 Revision D](#).
- Do not pull a vacuum over the port hole of the microphone. Pulling a vacuum over the port hole can damage the device.
- Do not board wash after the reflow process. Board washing and cleaning agents can damage the device. Do not expose to ultrasonic processing or cleaning.
- Recommend no more than 5 cycles.
- Shelf life : Twelve(12) months when devices are to be stored in factory supplied, unopened ESD moisture sensitive bag under maximum environmental condition of 30°C, 70% R.H.
- Exposure : Devices should not be exposed to high humidity, high temperature environment. MSL (Moisture sensitivity level) Class 1.
- Out of bag : Maximum of 90 days of ESD moisture sensitive bag, assuming maximum conditions of 30°C, 70% R.H.

## 19. RECOMMENDED PICK-UP NOZZLE CONDITIONS

19.1. Nozzle material : Metal or Rubber, Etc.

19.2. Case Weight

- If tool outer size is bigger than MIC. : Max. 10N
- If tool outer size is smaller than MIC. : Max. 4N

19.3. Nozzle position : MIC. Center

- Nozzle inner diameter size : Max.  $\text{\O}1.5$

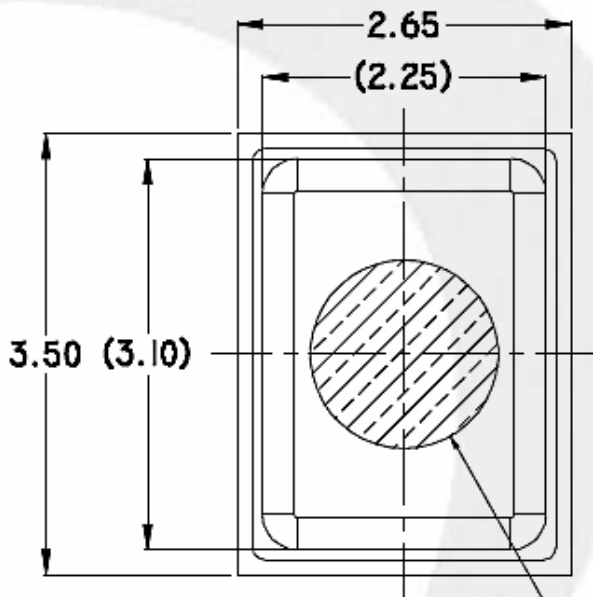
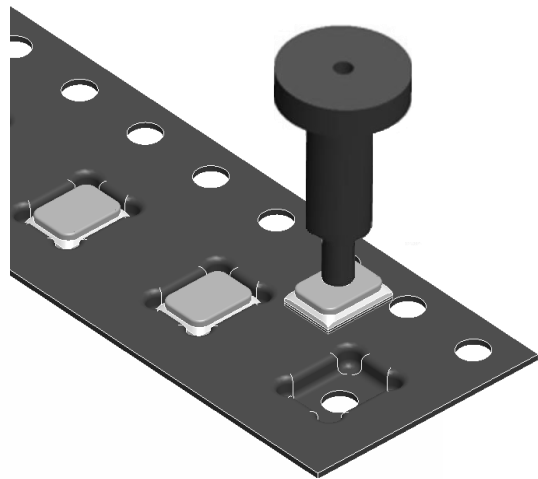
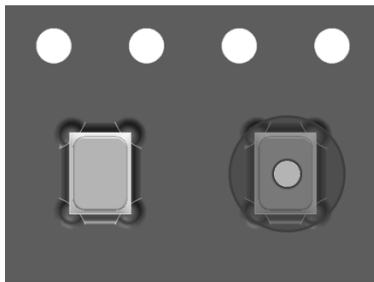

Max.  $\text{\O}1.50$ (Nozzle inner diameter)

**20. APPLICATION EXAMPLE**

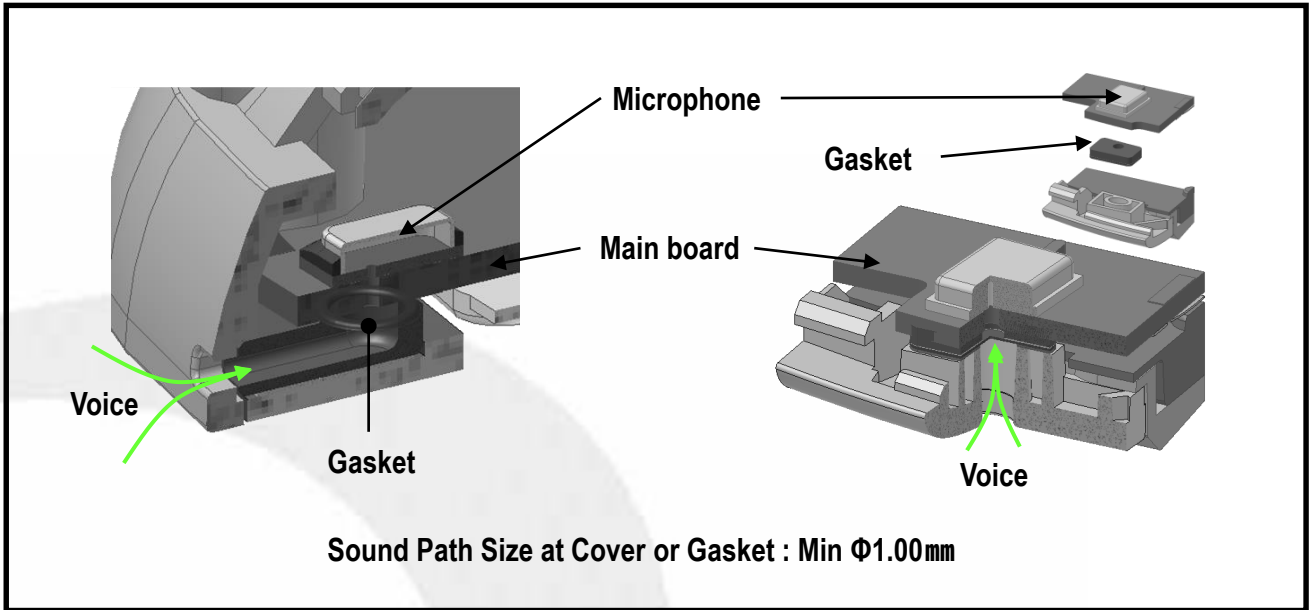
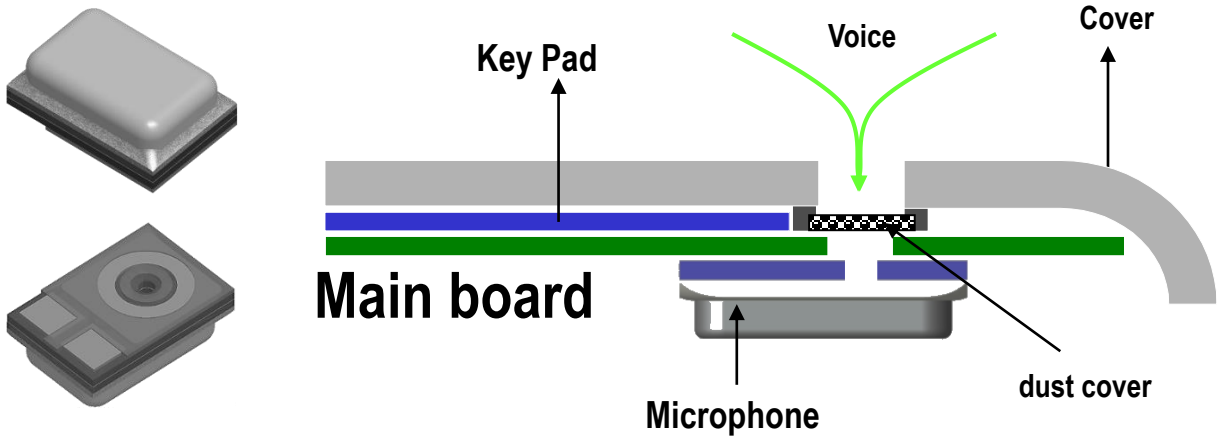

**Compression force for sealing**

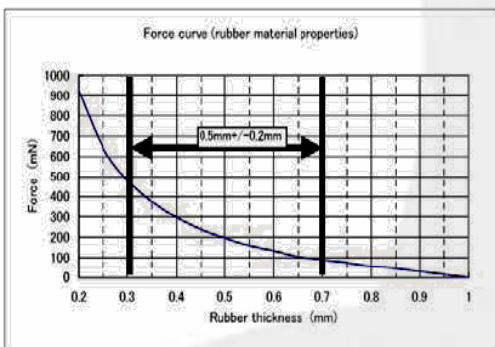

Gasket compression range for sealing  
→ 0.5±0.2mm

**Gasket Layers**

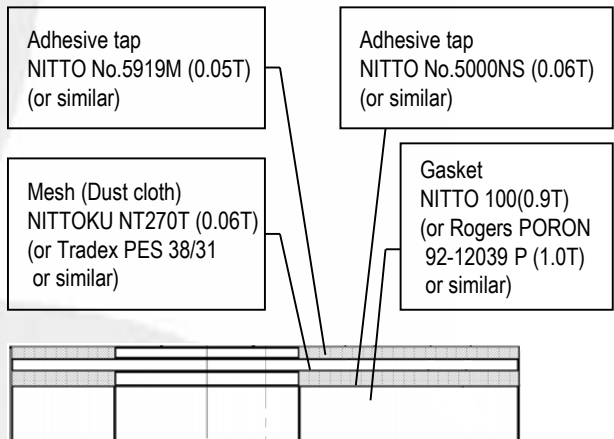

## 21. HANDLING GUIDE

### 21.1. Handling Guide of Cleaning & Foreign Matter

- \* Note 1. No Liquid or/and gas should be used for washing / cleaning.
- \* Note 2. No board washes should be applied after reflow
- \* Note 3. No foreign matter should be exposed interior microphone during cleaning or washing.  
if cleaning or washing is applied unavoidably, It must do additional prevention in area of "Microphone sound hole" to avoid foreign matter.(ex. Attached protective tape)
- \* Note 4. No seal sound hole of microphone should be applied during reflow process
- \* Note 5. No ultrasonic cleaning should be applied in case of microphone unit itself or/and after installed microphone onto board.
- \* Note 6. Do not reuse microphone which is defect during SMD.  
Do not wash or clean to reuse microphone which is defect during SMD.

De-cap View of  
Good part

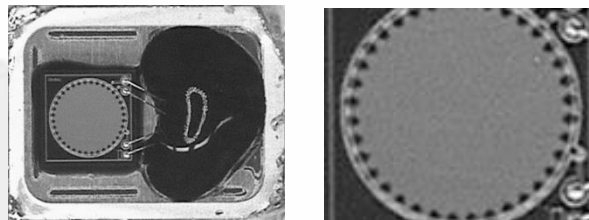

#### ► Example) De-cap View of the NG Microphone

Reflow after sealing of Sound Hole

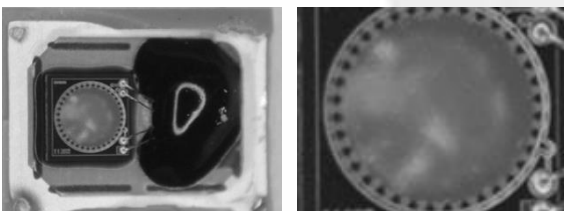

Defect view NG MIC by Pick-up

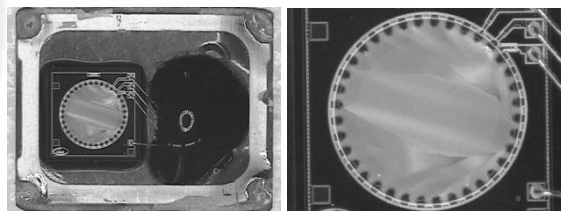

Defect view NG MIC by ultrasonic cleaning

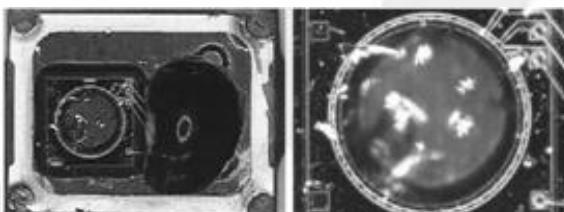

Defect view NG MIC by liquid foreign matter

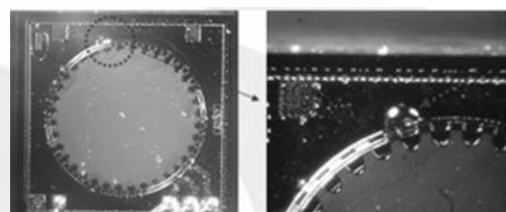

## 21. HANDLING GUIDE

### 21.2. Handling Guide of Care of Board Routing & Cutting

- \* Note 1. Do work maximum distance with microphone and minimum speed machining setting during Board Routing & Cutting
- \* Note 2. Do not wash or clean "Board" after Board Routing & Cutting
- \* Note 3. Do additional prevention in area of "microphone sound hole" to avoid foreign matter(ex. Attached protective tape) during Board Routing & Cutting
- \* Note 4. Do not use strong air flow directly in order to remove foreign matter should be applied in microphone
- \* Note 5. Do preventive action in area of "microphone sound hole" to avoid foreign matter(ex. Attached protective tape) or air .  
(ex. Block "Microphone sound hole" by hands as below picture)

#### ► Example) Air Blowing Condition

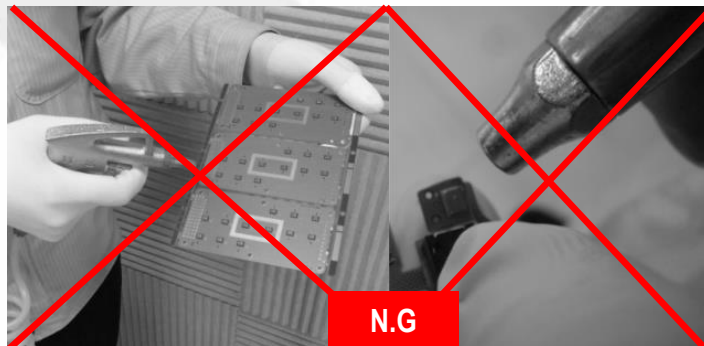

Example) Do block "Microphone Sound Hole" by hands during air blow

## 21. HANDLING GUIDE

### 21.3. Broken Membrane & Back Plate of MEMS DIE

\* Note 1. Do not touch Sound Hole by Sharp Tools. (ex. Tweezers)

\* Note 2. Do not rub Sound Hole by Swab. (ex. Cloth)

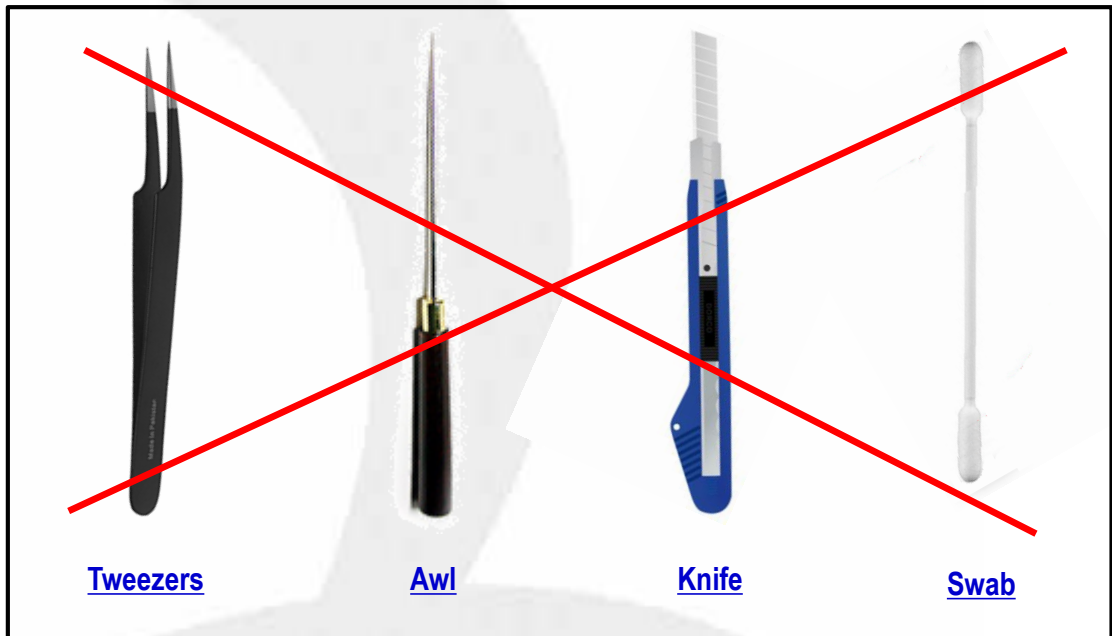
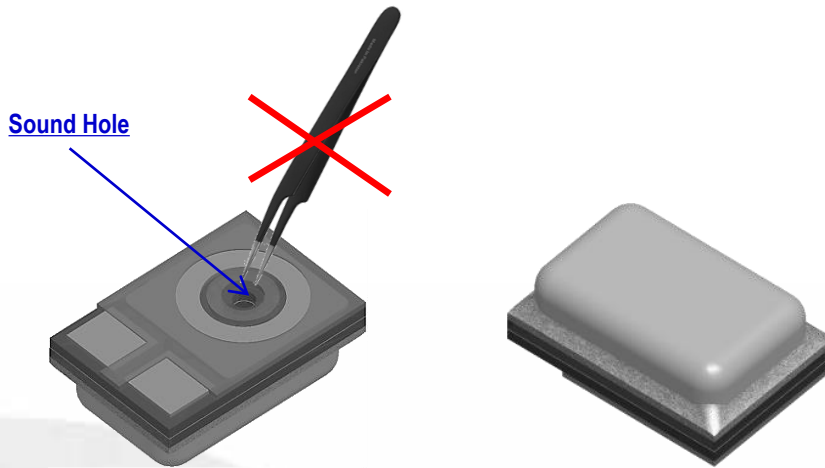

## 21. HANDLING GUIDE

### 21.4. PRECAUTION for ESD

\* Note 1. Wrist straps

Since the main cause of static is people, wrist-straps is very important to reduce the ESD damage. A wrist-strap, when properly grounded, keeps a person wearing it near ground potential and static charges do not accumulate. Wrist-straps should be worn by all personnel in all ESD protection areas, that is where ESD susceptible devices and end products containing them are assembled, manufactured handled and packaged.

Further ESD protection, similar to wrist-strap, involves the use of ESD protection floors in conjunction with ESD control footwear or foot-straps. Static control garments (smocks) give additional protection.

\* Note 2. Work Areas

It is recommended that all areas where components that are not in ESD protective packaging are handled should be designated as ESD protective areas. Ground mats of ESD safe table surfaces is needed. These should be connected to the local ground with a 1 Mega-ohm series resistor. ESD safe floor and shoes are also needed.

\* Note 3. Ionizers

In situations where we have to deal with isolated conductors that cannot be grounded and with most common plastics, air ionization can neutralize the static charge because only air is required for ionization to be effective, air ionizers can and should be used wherever it is not possible to ground everything.



## 21. HANDLING GUIDE

### 21.5. Inspection by X-Ray

\* Note 1. Do inspect X-Ray after SMD.

It is different X-Ray condition by applied SMD company.

**22. REWORK**

**22.1. Recommended Heater Gun Specification**

Manufacturer		HAKKO
Model		850B ESD
Temperature control		100 ~ 420
Top heater	Type	Hot air flow
	Flow rate	< 23 l/min
Alignment		visual
Pick-up		Manual
Solder/flux		1. Removing or pre-heating the solder residue before mounting new part 2. Apply lead-free flux only or apply 2 ~ 3 points of solder paste instead



**22.2. Recommended Heater Gun Setting Condition**

	Heater gun setting Temperature		300 °C ~ 400 °C
	Nozzle & MIC. Length		1.5 cm
	Flow setting		2.0 ~
	Alignment		Visual
	Pick-up		Manual
	Working Time	Remove	10 ~ 20 sec
SMD		10 ~ 20 sec	

\* Note 1. According to the material & thickness & counts of layer for PCB, this condition will be change.

\* Note 2. According to Rework M/C & Worker, this condition will be change.

**22. REWORK**

**22.3. Rework Process Condition (using Heater Gun)**

Bottom Heater	Recommend IR heater.
Alignment	Use magnifier for alignment. Note : it may difficult to do alignment by naked visual because MIC pad is located on soffit.
Temperature	Recommend temperature is “300°C”.
Time	It is the optimized working process of 1.0 ~ 2.0mm board for 10~20sec under 300°C temp.
Nozzle	Use heater gun without nozzle
Solder/flux Process Options	1. Removing the solder residue before mounting new part - print Halogen-free solder paste on the SMD MIC terminals using mask → mounting
	2-1. Pre-heating the solder residue before mounting new part - apply Halogen-free flux onto the land pattern
	2-2. Pre-heating the solder residue before mounting new part - apply 2 ~ 3 points of Halogen-free solder paste onto the land pattern
	3. <a href="#">Highly recommendation process for rework.</a> - After remove defect parts without Pre-heating, It is used Halogen-free flux or 2~3 points of Halogen-free solder. (It is most effective and fast for rework)

## 22. REWORK

### 22.4. Handling of Rework

- \* Note 1. Follow standard guide line of SMD company for Rework Condition
- \* Note 2. Rework conditions may variable by SMD companies' circumstance and working condition.
- \* Note 3. **Do Not reuse defect microphone by SMD process.**
- \* Note 4. **Do not employ chemical board wash or cleaning, as the associated cleaning agents (such as liquid or air) can damage the device.**

## SPECIFICATION HISTORY

Version	Date	Comments
1.0	Aug. 22. 22	1 <sup>st</sup> Submission of Electro-Acoustical specification

**Best sound electronics**  
Value no1. Micro sound provider

**— Address**

193, Namdongseo-ro, Namdong-gu, Incheon,  
South Korea

**— Contact**

TEL : +82-32-500-1700~7  
FAX : +82-32-554-6205~6

<http://www.globalbse.net>