

F4-(A)MOE-C110R38-6P

Narrow Sensitivity / Wide Band

OMNI-DIRECTIONAL
Bottom PORT

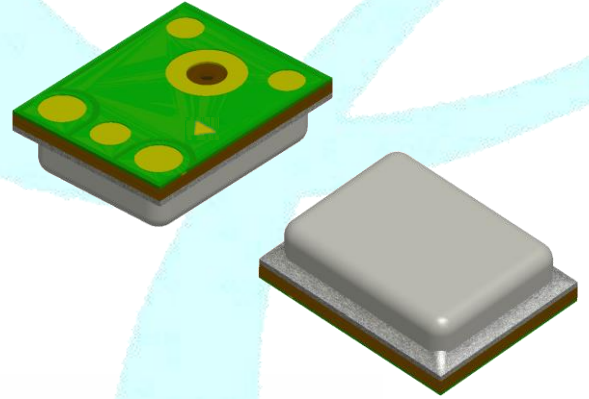

Best sound electronics

Value no1. Micro sound provider

Creative technology starts from respecting of life of the individuals

Creative technologies to respect human life



Best sound electronics

Value no1. Micro sound provider

We offer you happiness with our excellent technology beyond an ordinary sound what you expect

Superior technology to deliver happiness



Best sound electronics

Value no1. Micro sound provider

Keep basic fundamentals to fill sound with new innovations

Creative technologies to respect human life



1. INTRODUCTION

- Analog MEMS Microphone
- Single Mode
- Bottom Port Type - Sensitivity is Typical -38dBV/Pa
- **Signal to Noise Ratio (SNR) – Typical 63dB (A-weighted, 20Hz~20kHz)**
- **Wide Band – Flat Frequency Response, ± 2 dB at 100Hz ~ 8000 Hz (reference page 5)**
- **Narrow Sensitivity – ± 1 dB**
- Omni-directional
- RF Shielded – with embedded Capacitor
- Compatible with Sn/Pb and Halogen-free solder process
- RoHS compliant
- SMD reflow temperature of up to 260°C for over 30 seconds

2. APPLICATIONS

- Smartphones
- Ear-sets, Bluetooth Headsets
- Smart Speaker, Set Top Box
- Tablet Computers
- Wearable Devices
- Electrical Appliances
- Voice Recognition Systems of Appliances

3. MODEL NO.

F4-(A)HMOE-C110R38-6P

4. ABSOLUTE MAXIMUM RATINGS

Parameter	Absolute maximum rating	Units
Vdd to Ground	-0.3 to +3.6	V
OUT to Ground	-0.3 to Vdd+0.3	V
Input Current to Any Pin	1	mA

Caution : Stresses above those listed in “Absolute maximum ratings” may cause permanent damage to the device. These are stress ratings only. Functional operation at these or any other conditions beyond those indicated under “ELECTRO-ACOUSTIC CHARACTERISTICS” is not implied. Exposure beyond those indicated under “ELECTRO-ACOUSTIC CHARACTERISTICS” for extended periods may affect device reliability.

5. ELECTRO-ACOUSTIC CHARACTERISTICS

Test Condition : 23 ± 2°C, Room Humidity = 55 ± 20 %, VDD=2.0V, unless otherwise noticed.

Parameter	Conditions	Min	Typ	Max	Units
Directivity		Omni-directional			
Operating Voltage (Vdd)		1.6	-	3.6	V
Sensitivity Change across Voltage	Vdd=1.6V~3.6V	No Change			dB
Sensitivity (S)	94dB SPL at 1kHz, 0dB=1V/Pa	-39	-38	-37	dBV/Pa
Output Impedance (Z_{OUT})	94dB SPL at 1kHz	-	-	200	Ω
Current Consumption (I_{dd})	Vdd=1.6~3.6V	70	-	170	μA
Signal to Noise Ratio (SNR)	94dB SPL at 1kHz, A-weighted (20Hz~20kHz)	-	63	-	dB(A)
Equivalent Input Noise (EIN)	94dB SPL at 1kHz, A-Weighted (20Hz ~20kHz)	-	31	-	dB(A)SPL
Power Supply Rejection (PSR)	100mVp-p square wave at 217Hz, Vdd=1.8V, A-weighted	-	-94	-	dBV(A)
Power Supply Rejection Ratio (PSRR)	200mVp-p sine wave at 1kHz, Vdd=1.8V	-	62	-	dB
Low Frequency Roll Off (LFRO)	-3dB relative to 1kHz	-	80	-	Hz
Total Harmonic Distortion (THD)	94dB SPL at 1kHz	-	-	0.2	%
	113.5dB SPL at 1kHz	-	-	1.0	
	120.5dB SPL at 1kHz	-	-	3.0	
	122dB SPL at 1kHz	-	-	5.0	
Acoustic Overload Point (AOP)	THD>10% at 1kHz	123	124	-	dB SPL
DC Output Voltage	Vdd=1.6~3.6V	-	0.85	-	V
Start-up time	Vdd=1.6~3.6V	0.1	-	100	ms

6. MEASUREMENT CIRCUIT

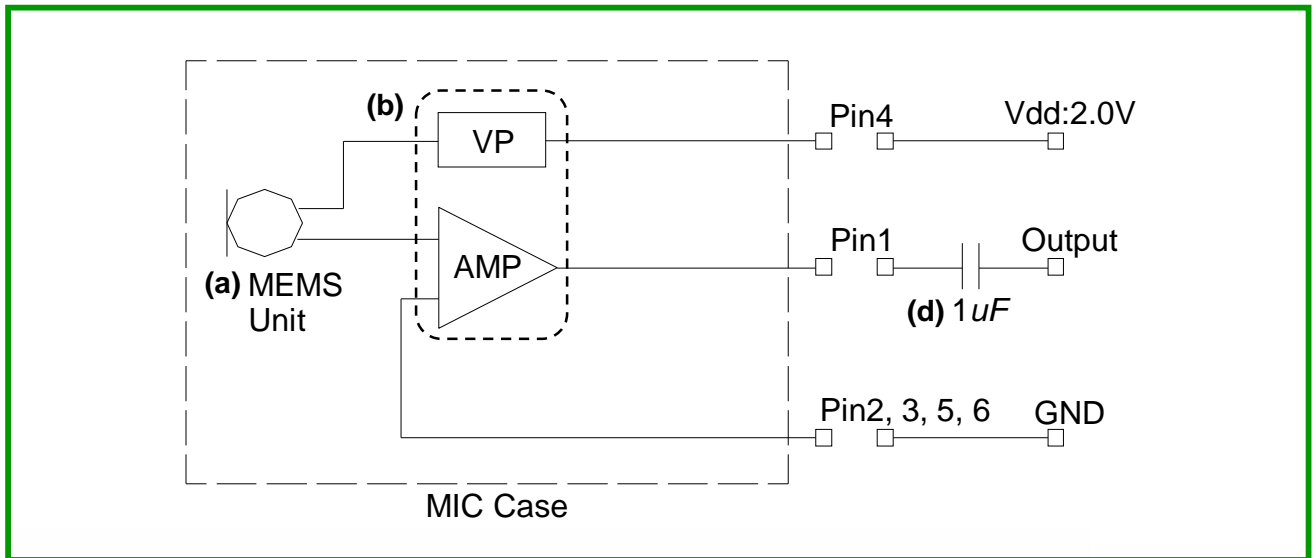

- (a) **MEMS Unit** : Membrane & Back Plate (transmit the electric signal modified from sound signal to ASIC)
- (b) **ASIC** : Impedance converter (Mechanical Signal → Electric Signal)
- (c) **Vdd** : Power Supply (Operation of ASIC)
- (d) **Rectifier Capacitor** : Removed Direct Current Factor
- (e) **Output** : Output Signal of Microphone's Sensitivity
- (f) **GND** : Ground

7. RECOMMENDED INTERFACE CIRCUIT

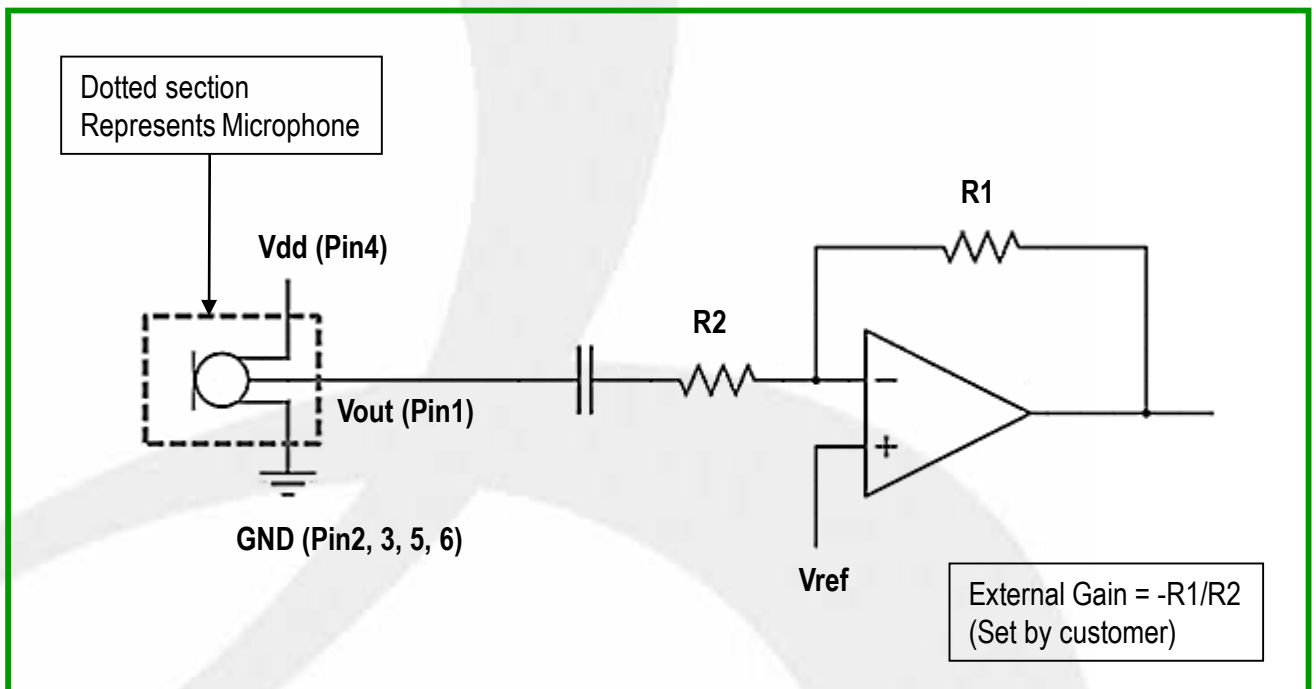

8. TYPICAL FREQUENCY RESPONSE CURVE(FAR FIELD)

Far Field Measurement Condition

Temperature : 23 ± 2 °C

Supply Voltage : 2.0V

Acoustic stimulus : 1Pa (94dB SPL at 1kHz) at 50 cm from the loud-speaker.

The loud-speaker must be calibrated to make a flat frequency response input signal.

Position : The frequency response of microphone unit measured at 50cm from the loud-speaker.

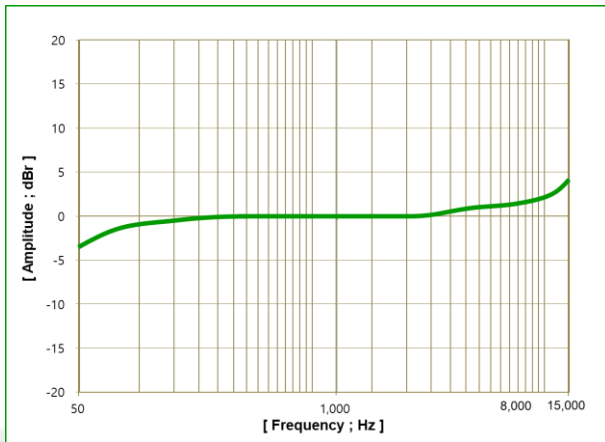

Figure 1. Typical Frequency Response, Normalized to 1kHz

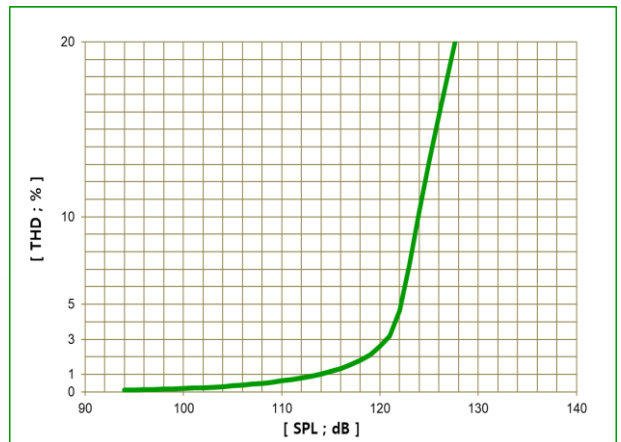

Figure 2. THD vs. Input Level

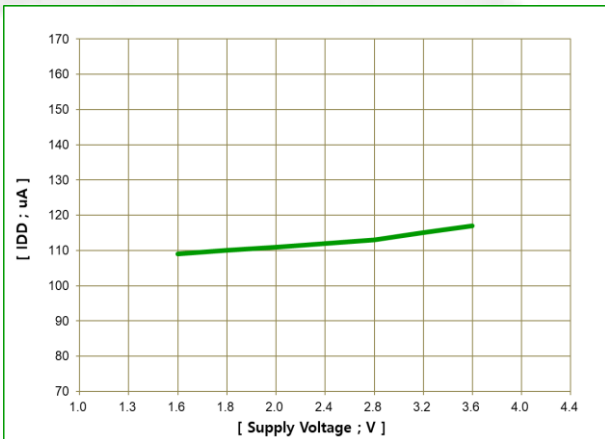

Figure 3. Typical IDD

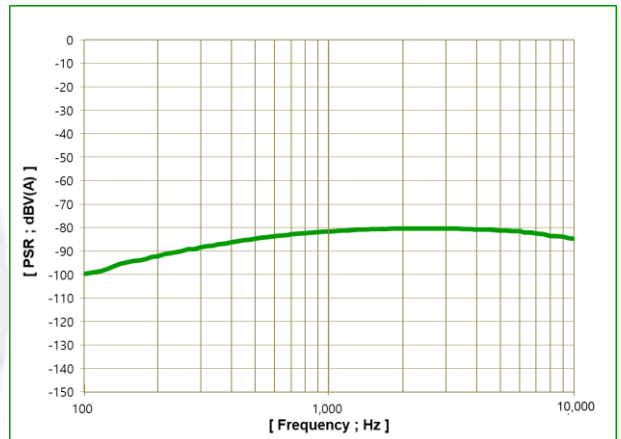

Figure 4. Typical Power Supply Rejection (PSR)

Frequency Mask Specification

Frequency [Hz]	Lower Limit [dB]	Upper Limit [dB]	Note
50 ~ 1000	-2	+2	0dB = dBV/Pa at 1kHz
1000	0	0	
1000 ~ 15000	-2	+2	

Note : Band Frequency Range

- 1. Narrow Band : 300Hz ~ 3.4kHz
- 2. Wide Band : 100Hz ~ 7kHz
- 3. Super Wide Band : 50Hz ~ 14kHz

9. MECHANICAL CHARACTERISTICS

※ PCB design & Pin size can be changed by model No.

SMD Type

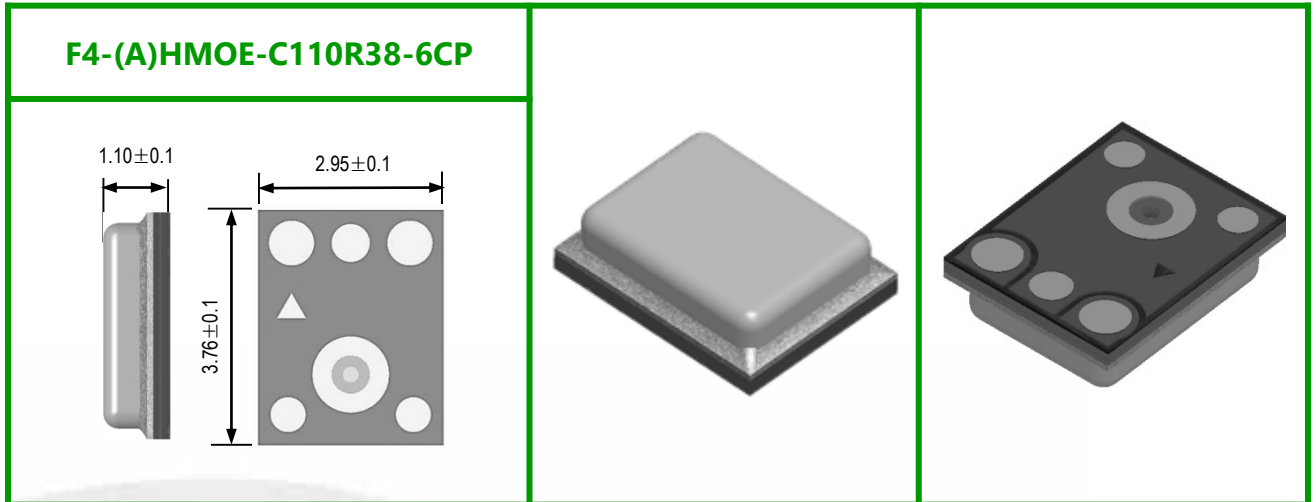

Lettering

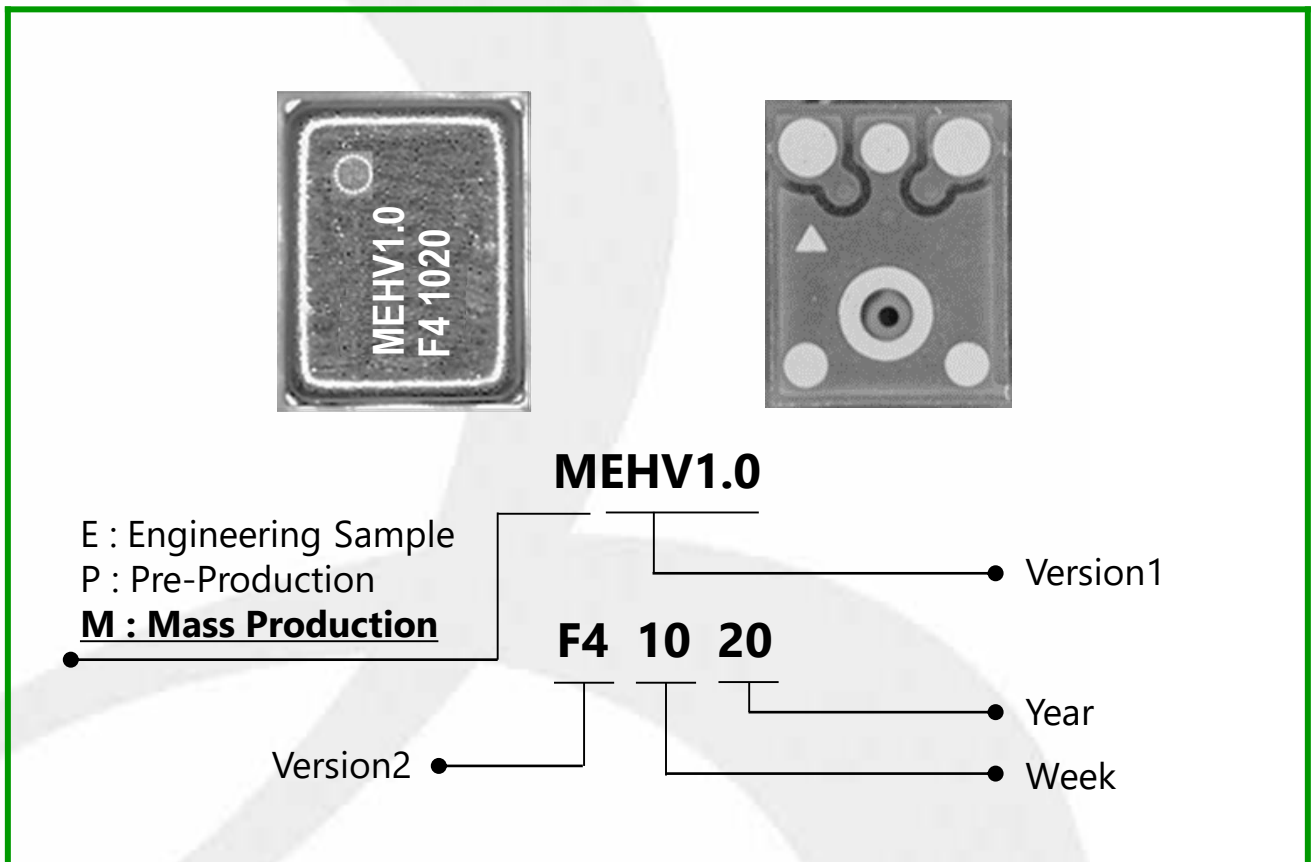

9. MECHANICAL CHARACTERISTICS

- Mechanical dimensions & Pad Lay-out

Dimensions (Unit : mm)

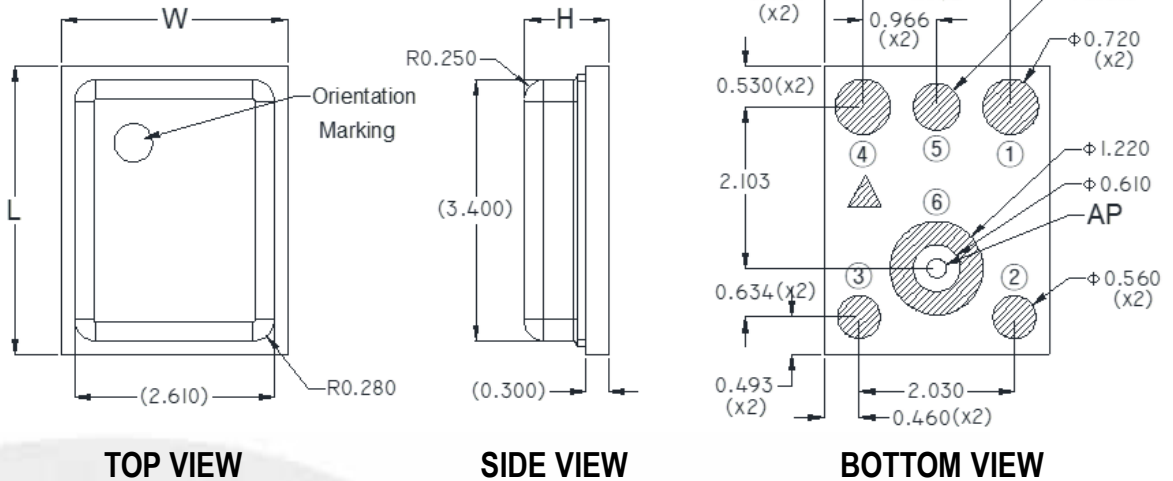

Item	Dimension	Tolerance (+/-)	Units
Length (L)	3.76	0.10	mm
Width (W)	2.95	0.10	mm
Height (H)	1.10	0.10	mm
Acoustic Port (AP)	$\phi 0.25$	0.05	mm

Pin #	Pin Name	Type	Description
1	Output (Vout)	Signal	Output Signal
2	GND	Ground	Ground
3	GND	Ground	Ground
4	Power (VDD)	Power	Power Supply
5	GND	Ground	Ground
6	GND	Ground	Ground

**Note : All ground Pins must be connected to ground.
 "6" Pin must be sealed by solder paste on the phone PWB.
 General Tolerance ± 0.08 mm.**

9. MECHANICAL CHARACTERISTICS

- Recommended Land Pattern & Stencil Pattern

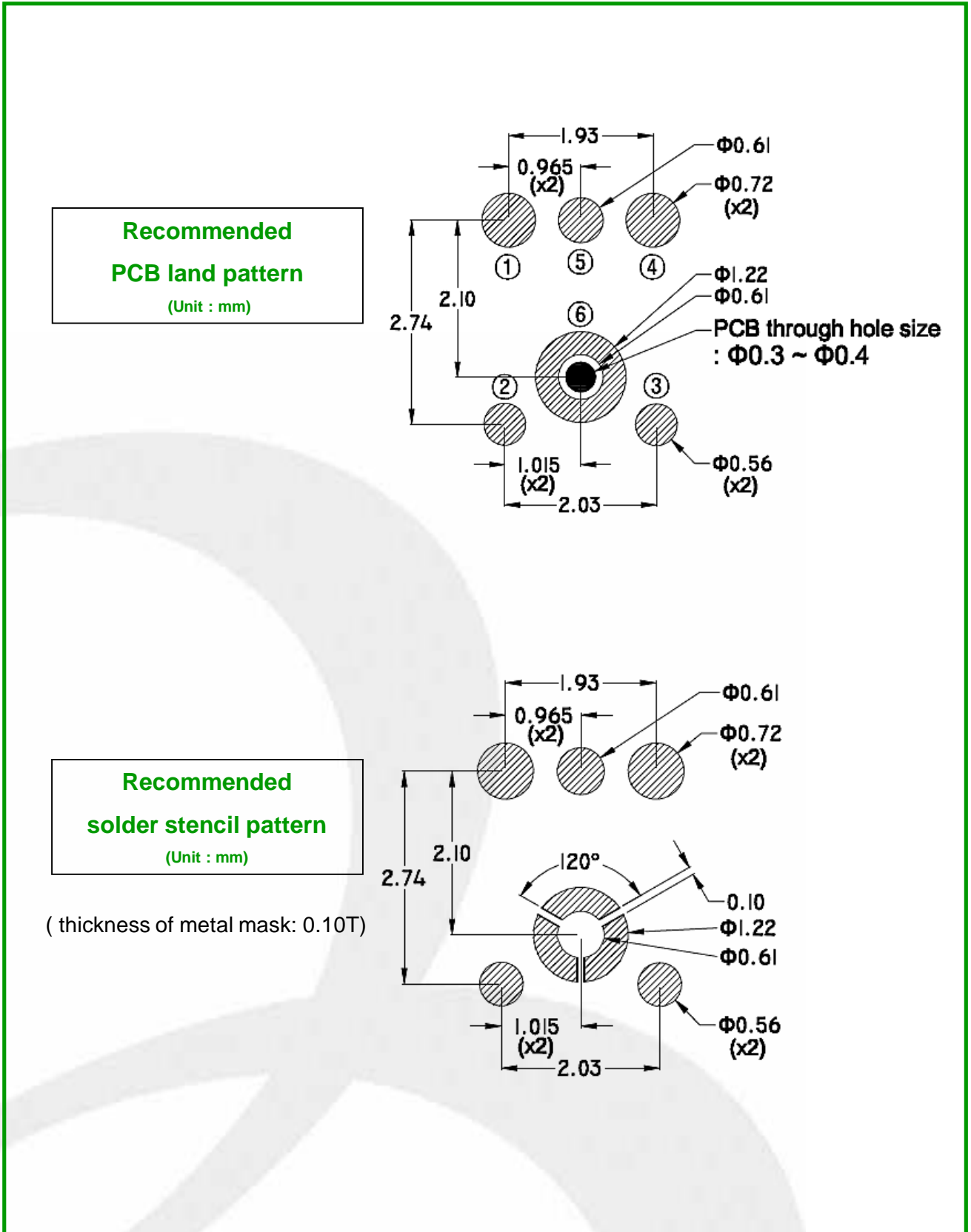

10. PACKAGING SPECIFICATION

- Reel

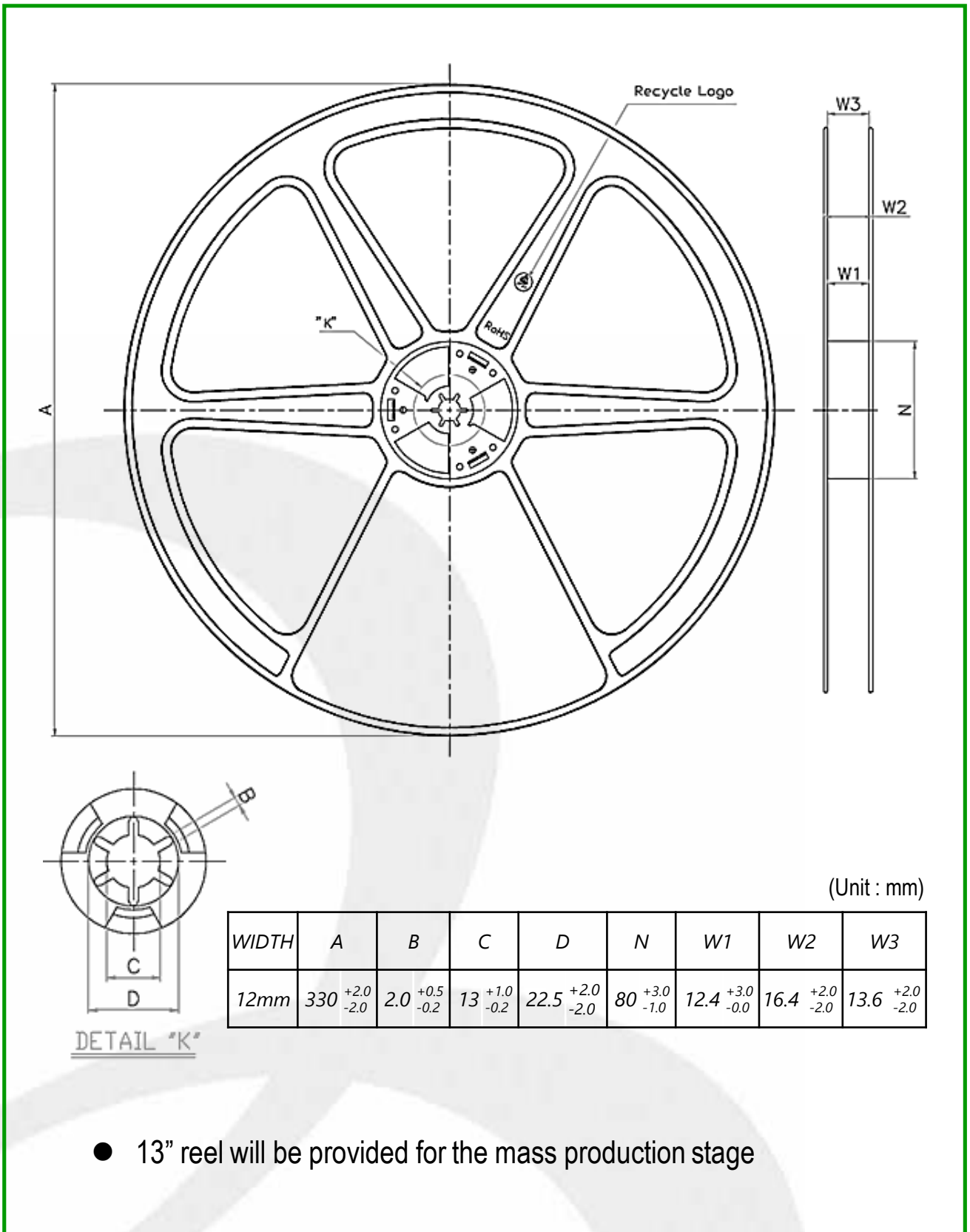

10. PACKAGING SPECIFICATION

- Taping

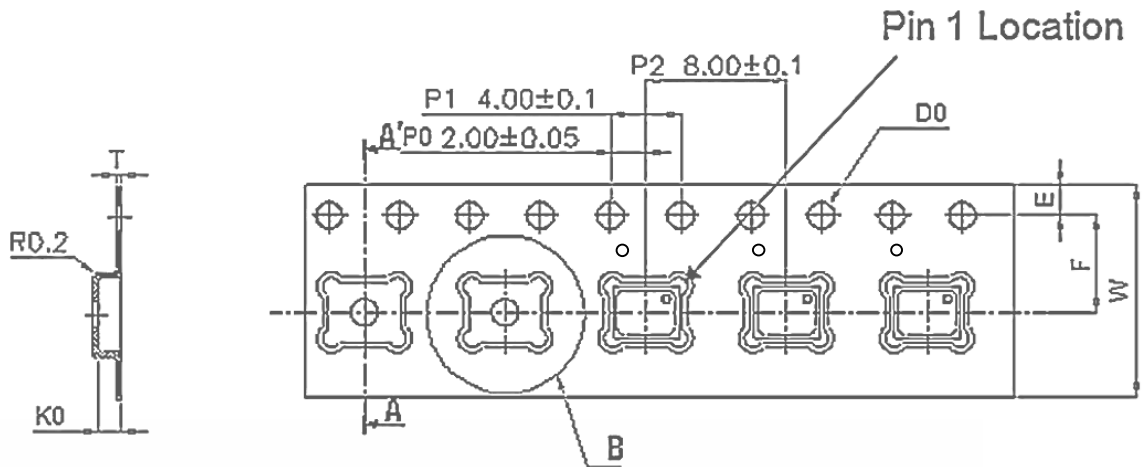

SECTION A-A'

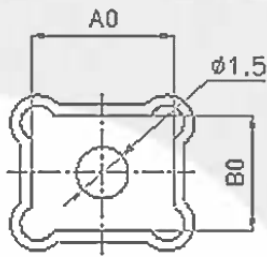

DETAIL B (2:1)

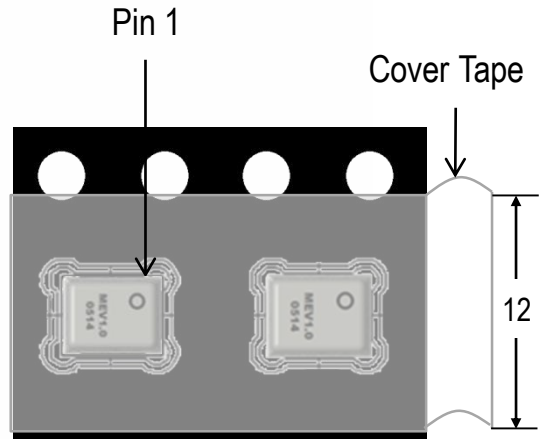

[Note]

1. Direction of parts : See above pictures.
2. Microphone total quantity (13" Reel) : 5,700pcs
3. Carrier Tape ESD : $10^2 \sim 10^{10} \Omega$
4. Cover Tape Inside ESD : $10^2 \sim 10^{10} \Omega$
5. Carrier Tape Material & Color : PS, Black
6. Thermo Compression Bonding

Unit : mm

A0	4.06±0.10	E	1.75±0.10
B0	3.30±0.10	F	5.50±0.05
K0	1.30±0.10	T	0.30±0.05
D0	1.50±0.10	W	12.00±0.30

10. PACKAGING SPECIFICATION

- Packing

Inner Box spec.

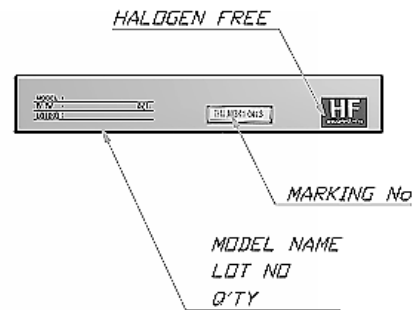
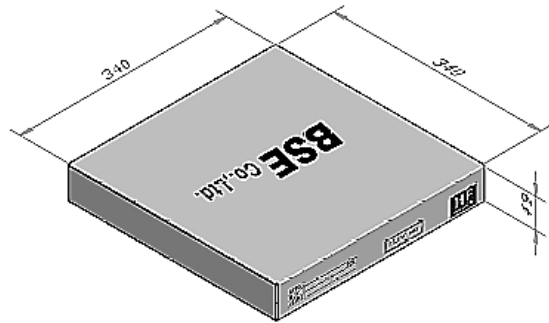
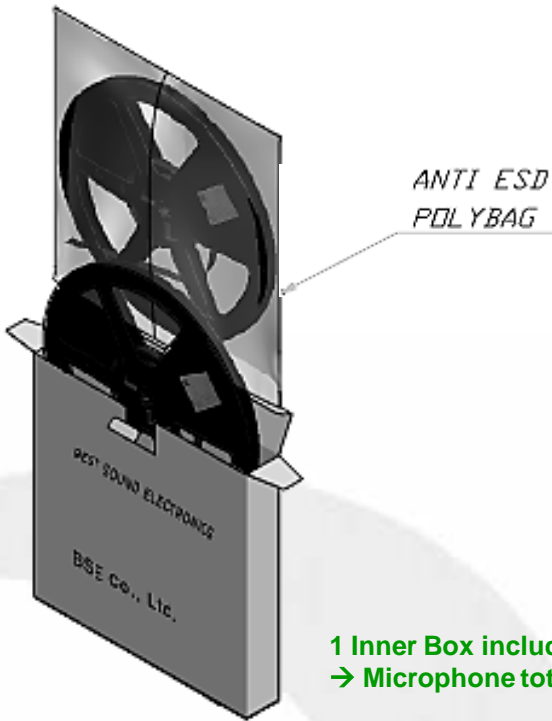

1 Inner Box included 2 reels
→ Microphone total quantity : 11,400 pcs

Outer Box Spec.

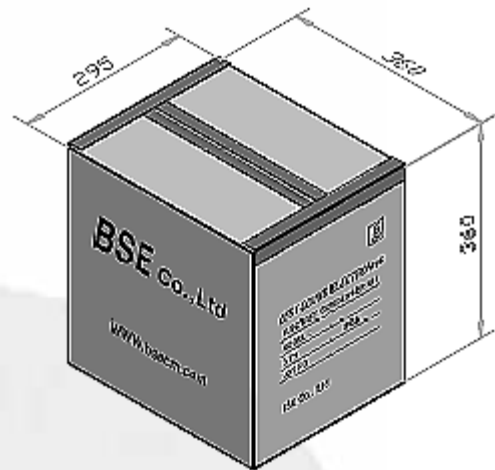

1 Outer Box included 5 Inner Boxes
→ Microphone total quantity : 57,000 pcs

11. RELIABILITY TEST CONDITIONS

Note : After test conditions are performed, the sensitivity of the microphone shall not deviate more than $\pm 1\text{dB}$ from its initial value.

TEST	DESCRIPTION
TEMPERATURE STORAGE	[High Temperature Storage] +80°C±3°C x 200hrs (The measurement to be done after 2 hours of conditioning at room temperature)
	[Low Temperature Storage] -30°C±3°C x 200hrs (The measurement to be done after 2 hours of conditioning at room temperature)
TEMPERATURE CYCLE	(-25°C±2°C x 30min -> +20°C±2°C x 10min -> +70°C±2°C x 30min -> +20°C±2°C x 10min) x 5cycles (The measurement to be done after 2 hours of conditioning at room temperature)
THERMAL SHOCK	(+85°C±2°C -> -40°C±2°C Change time : 20sec) x 96cycles Maintain : 30min (The measurement to be done after 2 hours of conditioning at room temperature)
HIGH TEMPERATURE AND HUMIDITY	+85°C±2, 85±%RH, Bias(3.6V) x 200hrs (The measurement to be done after 2 hours of conditioning at room temperature)
	+70°C±2, 95±%RH x 200hrs (The measurement to be done after 2 hours of conditioning at room temperature)
ESD (Electrostatic Discharge)	Air discharge : ±8kV, ±10kV, ±12kV, ±15kV Vdd, Vout, GND Pad each 5 times (Non-ground)
	Contact discharge : ±2kV, ±4kV, ±6kV, ±8kV Vdd, Vout, GND Pad each 5 times (Non-ground)
VIBRATION	Signal 5Hz to 500Hz, acceleration spectral density of 0.01g ² /Hz in each of 3 axes, 120 min in each axis (360min in total)
DROP	To be no interference in operation after dropped to steel floor 18 times from 1.52 meter height in state of packing
REFLOW SENSITIVITY	5 reflow cycles. Refer to reflow profile from specification item 14.

12 . TEMPERATURE CONDITIONS (Maximum Ratings)

12.1 STORAGE TEMPERATURE : -40°C ~ +100°C

12.2 OPERATING TEMPERATURE : -40°C ~ +100°C

13. MEASUREMENT SYSTEM

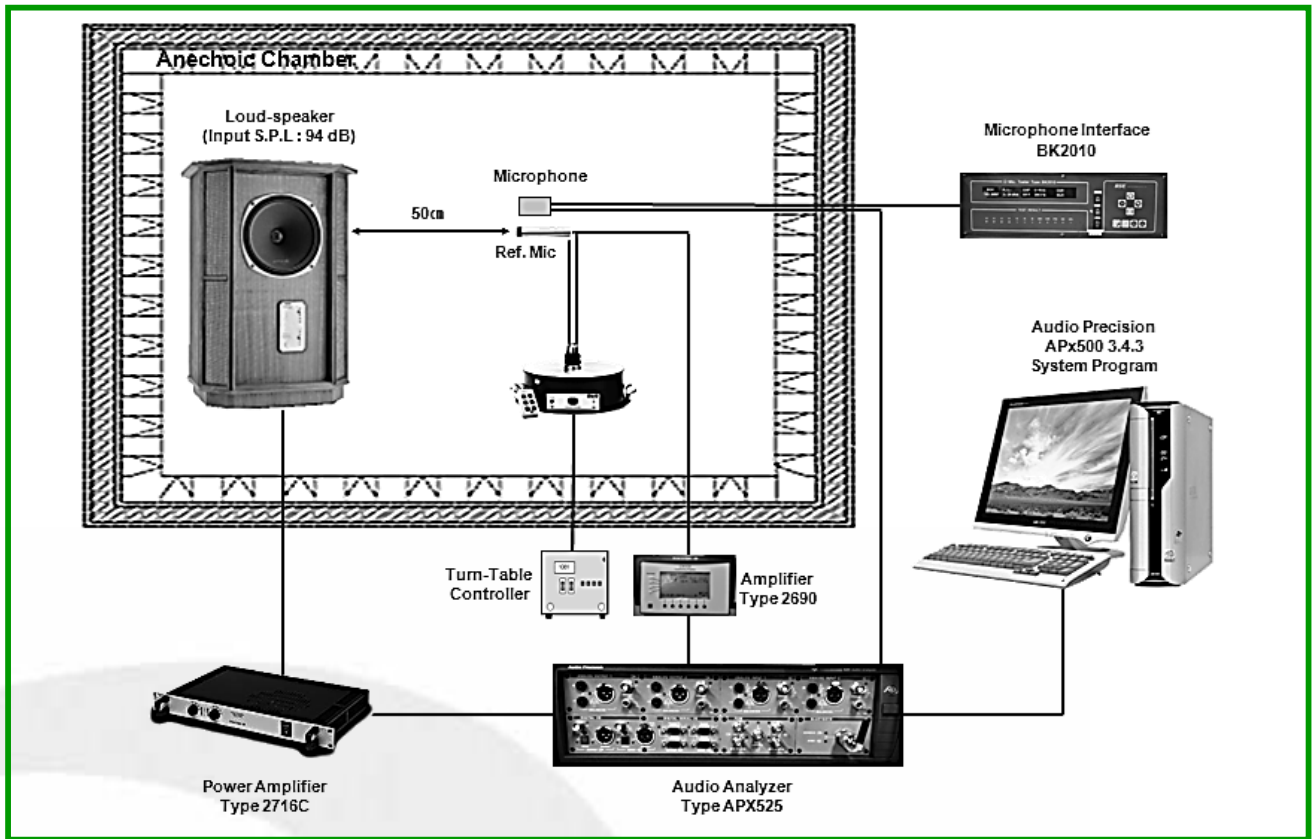

13.1 Measurement Condition

- (a) Supply voltage : 2.0V
- (b) Acoustic stimulus : 94dB SPL at 1kHz
- (c) Distance between MIC & SPK : 50cm
- (d) Measurement frequency : 50 (Hz) ~ 20 (kHz)

Machine	Model No	Purpose
Standard MIC	4191	Revision of input signal & SPK spec
Audio Analyzer	APX525	Audio Analysis (include Power Supply)
Loud-speaker	GRF Memory HE	SPK (Input sound Signal occur)
Power Amplifier	2716C	Power amplification
Charging Conditioning Amplifier	2690	Ref. MIC Signal Transformation
Microphone Interface	BK2010	Voltage & impedance supply to MIC
Operating Software	APx500 3.4.4	A-D Freq. Resp.
Sound Level Calibrator	4231	Standard MIC Calibration purpose

14. SOLDER REFLOW PROFILE

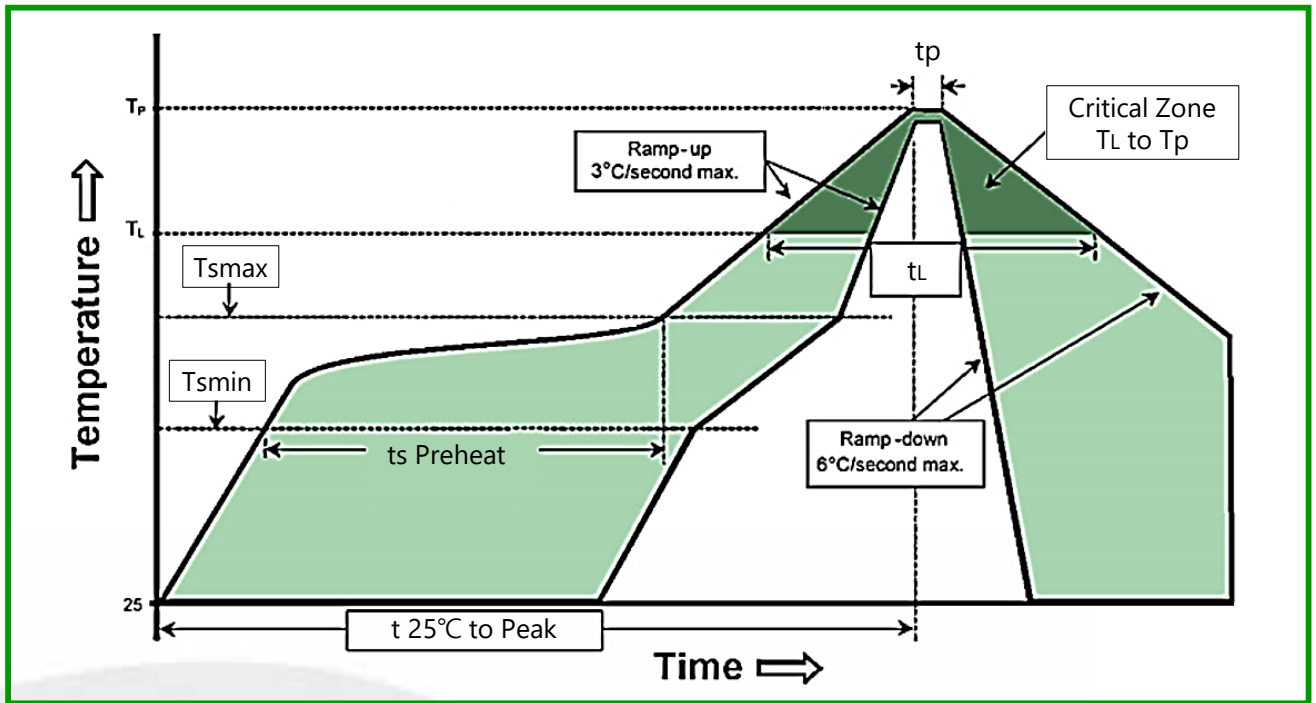

Profile Feature	Pb-Free Assembly
Preheat/Soak	
Temperature Min (Tsmmin)	150°C
Temperature Min (Tsmmax)	200°C
Time(ts) from (Tsmmin to Tsmmax)	60 ~ 120 seconds
Ramp-up rate (TL to Tp)	3°C/second max.
Liquidous temperature(TL)	217°C
Time(tL) maintained above TL	60 ~ 150 seconds
Peak package body temperature (Tp)	260°C
Time(tp) within 5°C of the specified classification Temperature(Tc)	20 ~ 40 seconds
Ramp-down rate (Tp to TL)	6°C/second max.
Time 25°C to peak temperature	8 minutes max.

[Notes]

1. Solder Reflow Profile based on [IPC/JDEC J-STD-020 Revision D](#).
2. Do not pull a vacuum over the port hole of the microphone. Pulling a vacuum over the port hole can damage the device.
3. Do not board wash after the reflow process. Board washing and cleaning agents can damage the device. Do not expose to ultrasonic processing or cleaning.
4. Recommend no more than 5 cycles.
5. Shelf life : Twelve(12) months when devices are to be stored in factory supplied, unopened ESD moisture sensitive bag under maximum environmental condition of 30°C, 70% R.H.
6. Exposure : Devices should not be exposed to high humidity, high temperature environment. MSL (Moisture sensitivity level) Class 1.
7. Out of bag : Maximum of 90 days of ESD moisture sensitive bag, assuming maximum conditions of 30°C, 70% R.H.

15. RECOMMENDED PICK-UP NOZZLE CONDITIONS

15.1. Nozzle material : Metal or Rubber, Etc.

15.2. Case Weight

- If tool outer size is bigger than MIC. : Max. 10N
- If tool outer size is smaller than MIC. : Max. 4N

15.3. Nozzle position : MIC Center

- Nozzle inner diameter size : Max. $\text{\O}1.90$

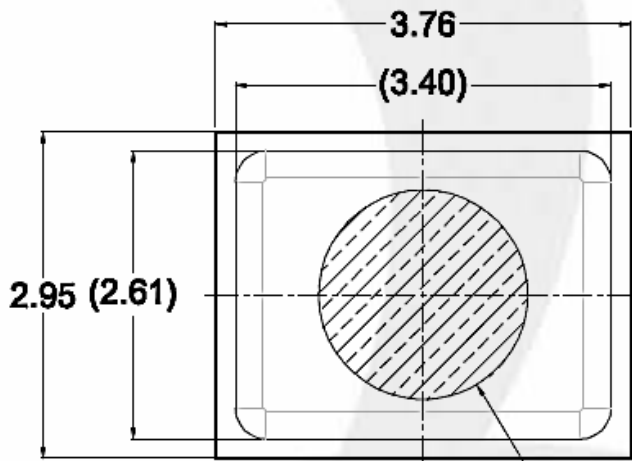
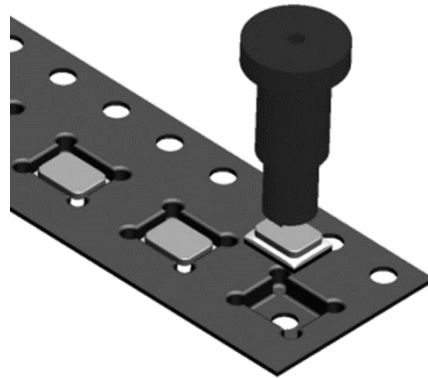
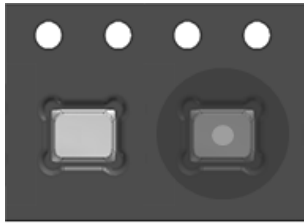

Max. $\text{\O}1.90$ (Nozzle inner diameter)

16. APPLICATION EXAMPLE

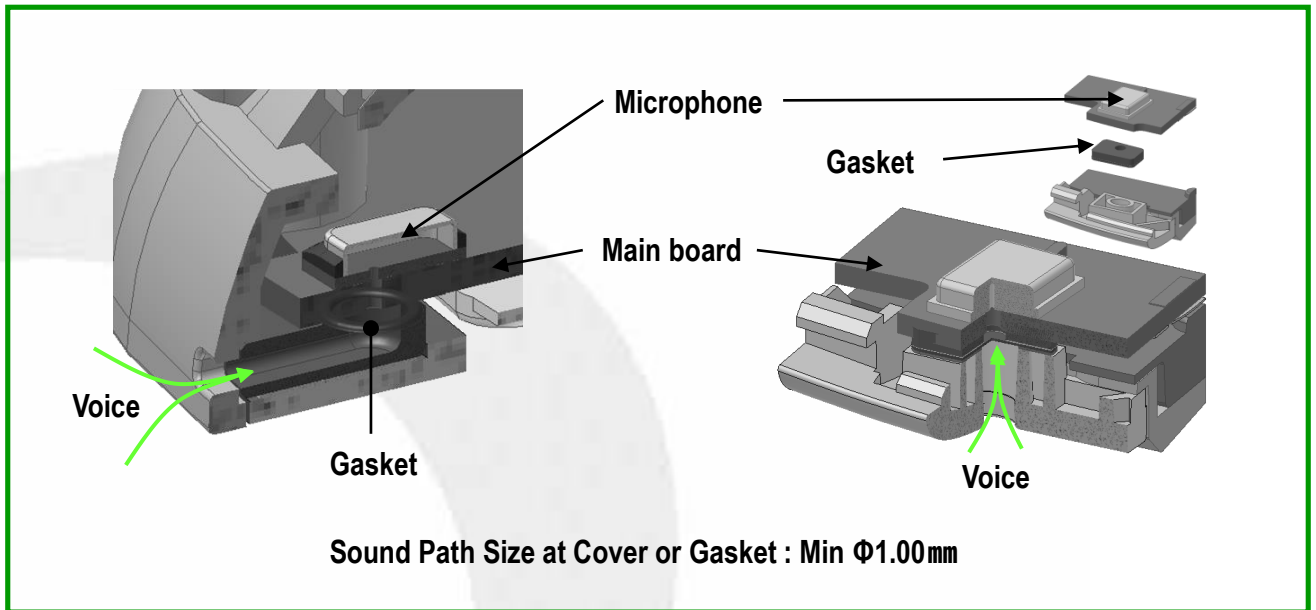
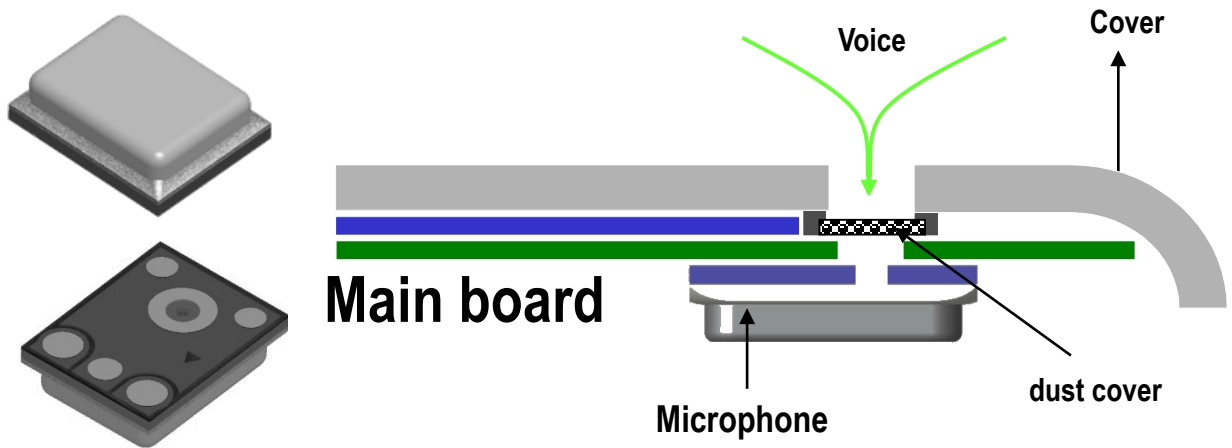

Compression force for sealing

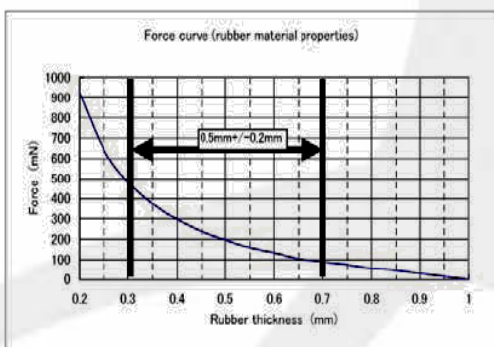

Gasket compression range for sealing
→ 0.5±0.2mm

Gasket Layers

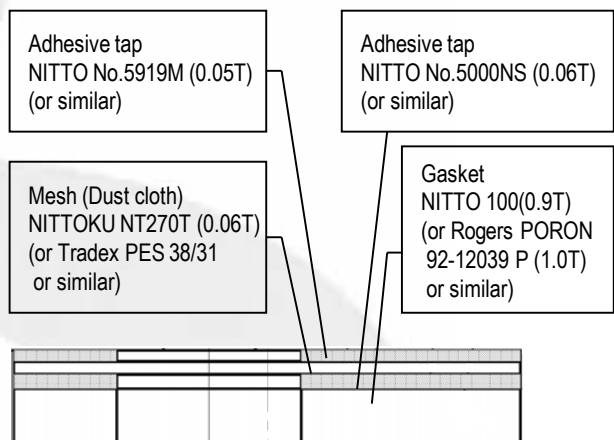

17. HANDLING GUIDE

17.1. Handling Guide of Cleaning & Foreign Matter

- * Note 1. No Liquid or/and gas should be used for washing / cleaning.
- * Note 2. No board washes should be applied after reflow
- * Note 3. No foreign matter should be exposed interior microphone during cleaning or washing.
if cleaning or washing is applied unavoidably, It must do additional prevention in area of
“Microphone sound hole” to avoid foreign matter.(ex. Attached protective tape)
- * Note 4. No seal sound hole of microphone should be applied during reflow process
- * Note 5. No ultrasonic cleaning should be applied in case of microphone unit itself or/and after
installed microphone onto board.
- * Note 6. Do not reuse microphone which is defect during SMD.
Do not wash or clean to reuse microphone which is defect during SMD.

De-cap View of
Good part

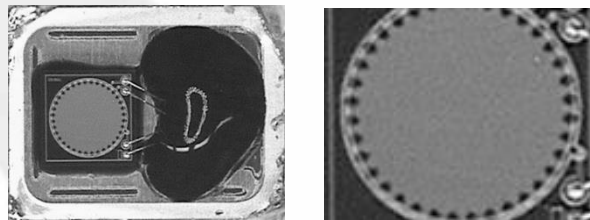

► Example) De-cap View of the NG Microphone

Reflow after sealing of Sound Hole

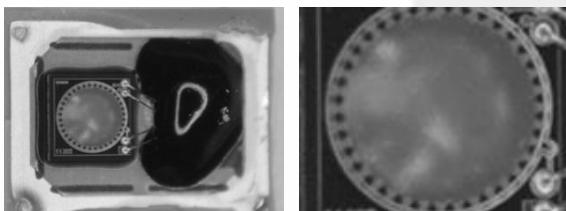

Defect view NG MIC by Pick-up

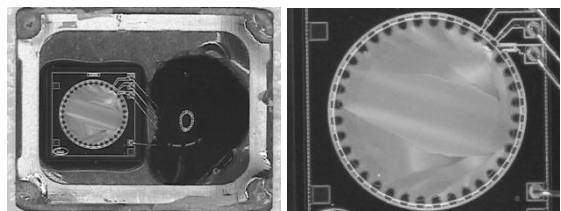

Defect view NG MIC by ultrasonic cleaning

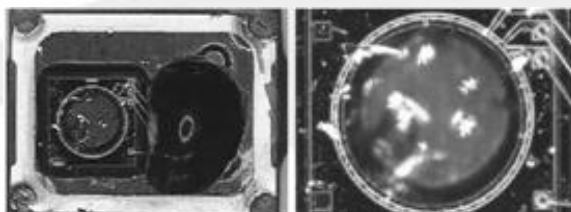

Defect view NG MIC by liquid foreign matter

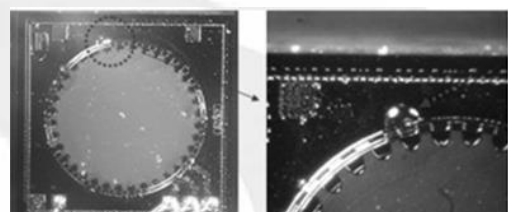

17. HANDLING GUIDE

17.2. Handling Guide of Care of Board Routing & Cutting

- * Note 1. Do work maximum distance with microphone and minimum speed machining setting during Board Routing & Cutting
- * Note 2. Do not wash or clean “Board” after Board Routing & Cutting
- * Note 3. Do additional prevention in area of “microphone sound hole” to avoid foreign matter(ex. Attached protective tape) during Board Routing & Cutting
- * Note 4. Do not use strong air flow directly in order to remove foreign matter should be applied in microphone
- * Note 5. Do preventive action in area of “microphone sound hole” to avoid foreign matter(ex. Attached protective tape) or air.
(ex. Block “Microphone sound hole” by hands as below picture)

► Example) Air Blowing Condition

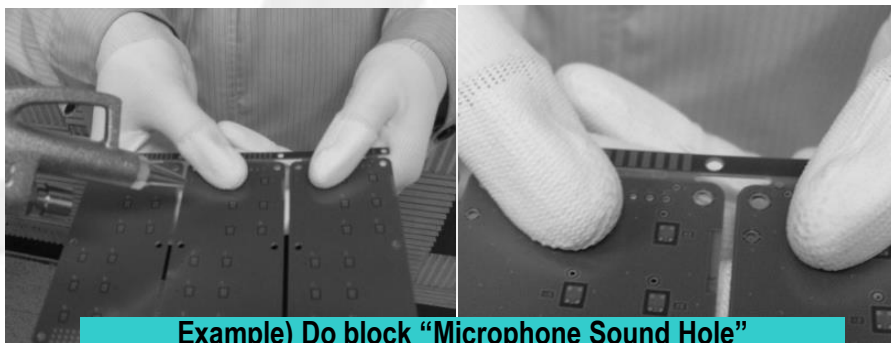
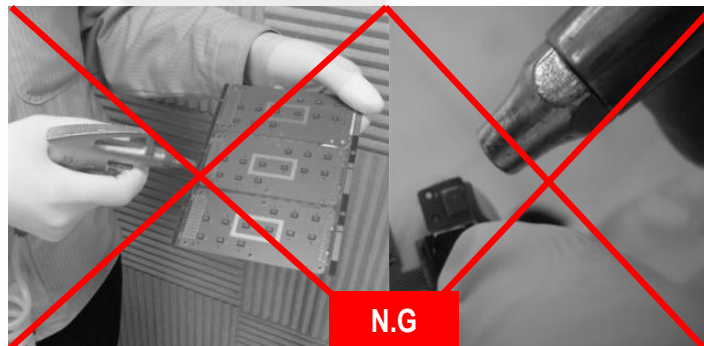

**Example) Do block “Microphone Sound Hole”
by hands during air blow**

17. HANDLING GUIDE

17.3. Broken Membrane & Back Plate of MEMS DIE

* Note 1. Do not touch Sound Hole by Sharp Tools. (ex. Tweezers)

* Note 2. Do not rub Sound Hole by Swab. (ex. Cloth)

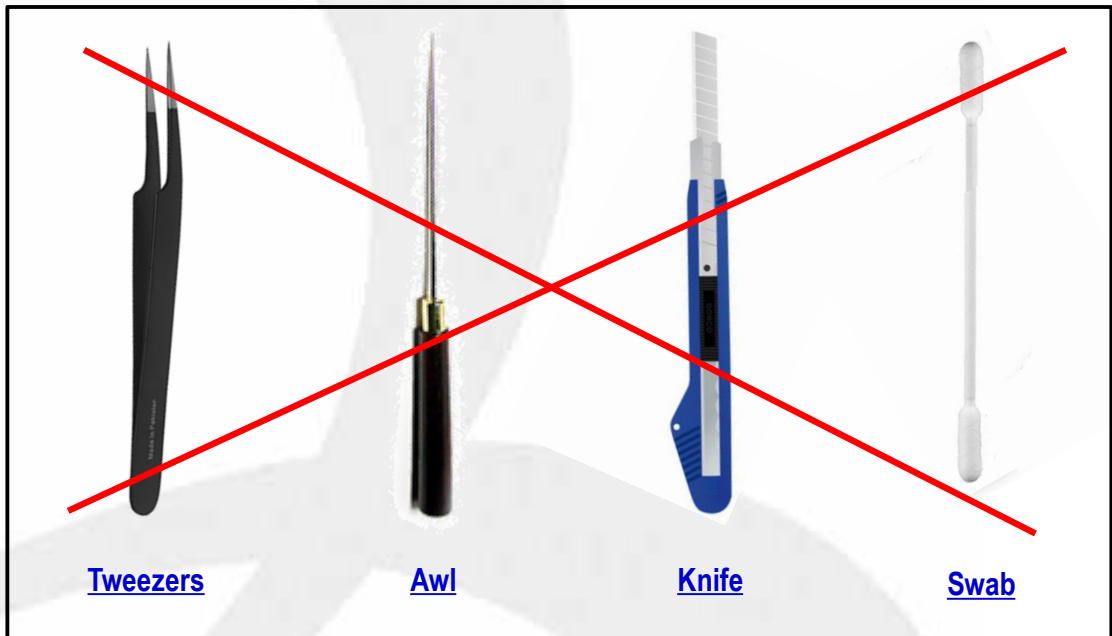
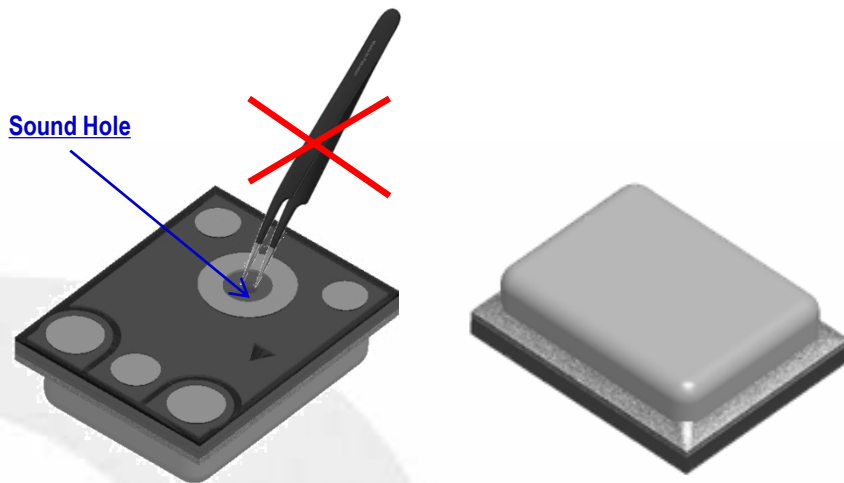

17. HANDLING GUIDE

17.4. PRECAUTION for ESD

* Note 1. Wrist straps

Since the main cause of static is people, wrist-straps is very important to reduce the ESD damage. A wrist-strap, when properly grounded, keeps a person wearing it near ground potential and static charges do not accumulate. Wrist-straps should be worn by all personnel in all ESD protection areas, that is where ESD susceptible devices and end products containing them are assembled, manufactured handled and packaged.

Further ESD protection, similar to wrist-strap, involves the use of ESD protection floors in conjunction with ESD control footwear or foot-straps. Static control garments (smocks) give additional protection.

* Note 2. Work Areas

It is recommended that all areas where components that are not in ESD protective packaging are handled should be designated as ESD protective areas. Ground mats of ESD safe table surfaces is needed. These should be connected to the local ground with a 1 Mega-ohm series resistor. ESD safe floor and shoes are also needed.

* Note 3. Ionizers

In situations where we have to deal with isolated conductors that cannot be grounded and with most common plastics, air ionization can neutralize the static charge because only air is required for ionization to be effective, air ionizers can and should be used wherever it is not possible to ground everything.

17. HANDLING GUIDE

17.5. Inspection by X-Ray

* Note 1. Do inspect X-Ray after SMD.

It is different X-Ray condition by applied SMD company.

18. REWORK

18.1. Recommended Heater Gun Specification

Manufacturer		HAKKO
Model		850B ESD
Temperature control		100 ~ 420
Top heater	Type	Hot air flow
	Flow rate	< 23 l/min
Alignment		visual
Pick-up		Manual
Solder/flux		1. Removing or pre-heating the solder residue before mounting new part 2. Apply lead-free flux only or apply 2 ~ 3 points of solder paste instead



18.2. Recommended Heater Gun Setting Condition

		Heater gun setting Temperature	300 °C ~ 400 °C
		Nozzle & MIC. Length	1.5 cm
		Flow setting	2.0 ~
		Alignment	Visual
		Pick-up	Manual
		Working Time	Remove
SMD	10 ~ 20 sec		

* Note 1. According to the material & thickness & counts of layer for PCB, this condition will be change.

* Note 2. According to Rework M/C & Worker, this condition will be change.

18. REWORK

18.3. Rework Process Condition (using Heater Gun)

Bottom Heater	Recommend IR heater.
Alignment	Use magnifier for alignment. Note : it may difficult to do alignment by naked visual because MIC pad is located on soffit.
Temperature	Recommend temperature is “300°C”.
Time	It is the optimized working process of 1.0 ~ 2.0mm board for 10~20sec under 300°C temp.
Nozzle	Use heater gun without nozzle
Solder/flux Process Options	1. Removing the solder residue before mounting new part - print Halogen-free solder paste on the SMD MIC terminals using mask → mounting
	2-1. Pre-heating the solder residue before mounting new part - apply Halogen-free flux onto the land pattern
	2-2. Pre-heating the solder residue before mounting new part - apply 2 ~ 3 points of Halogen-free solder paste onto the land pattern
	3. Highly recommendation process for rework. - After remove defect parts without Pre-heating, It is used Halogen-free flux or 2~3 points of Halogen-free solder. (It is most effective and fast for rework)

18. REWORK

18.4. Handling of Rework

- * Note 1. Follow standard guide line of SMD company for Rework Condition
- * Note 2. Rework conditions may variable by SMD companies' circumstance and working condition.
- * Note 3. Do Not reuse defect microphone by SMD process.
- * Note 4. Do not employ chemical board wash or cleaning, as the associated cleaning agents (such as liquid or air) can damage the device.

SPECIFICATION HISTORY

Version	Date	Comments
1.0	APR. 01. 20	1 st Submission of Electro-Acoustical specification

Best sound electronics
Value no1. Micro sound provider

— Address

193, Namdongseo-ro, Namdong-gu, Incheon, South Korea

— Contact

TEL : +82-32-500-1700~7
FAX : +82-32-554-6205~6

 <http://www.bsecm.com>