

ENERGIZER A23

Miniature Alkaline

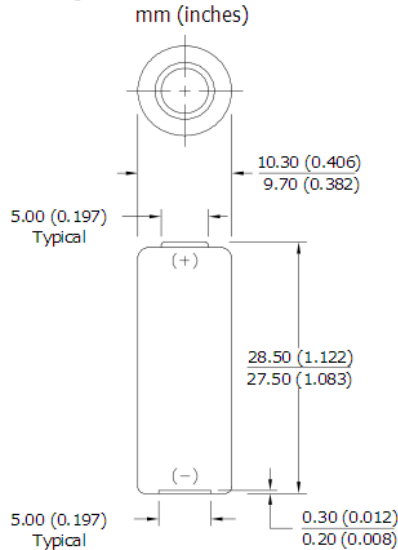

Industry Standard Dimensions



Designed for electronic applications which may require high rate pulses.

Specifications

Classification:	Miniature Alkaline
Chemical System:	Manganese Dioxide (MnO ₂)
Designation:	ANSI-1181A
Nominal Voltage:	12 volts
Typical Capacity:	55 mAh to 6.0 Volts (rated at 20K ohms at 21°C)
Typical Weight:	8.0 grams (0.3 oz.)
Typical Volume:	1.1 cubic centimeters (0.07 cubic inch)
Jacket:	Plastic Label
Terminal:	Flat Contact

Milliamp-Hours Capacity

Continuous discharge to 6.0 volts at 21°C

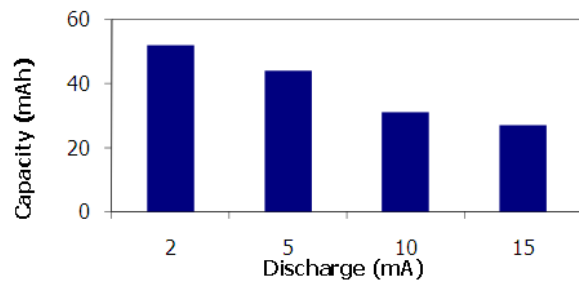

Typical Discharge Durations

Continuous discharge at 21°C

Schedule (time)	Drain (mA)	Load (ohms)	Cutoff Voltage		
			8.8V (hours)	7.2V (hours)	6.0V (hours)
Continuous	0.48	20K	81	105	115

Discharge Characteristics

Schedule: Continuous
Typical Load: 20 KΩ (21°C)

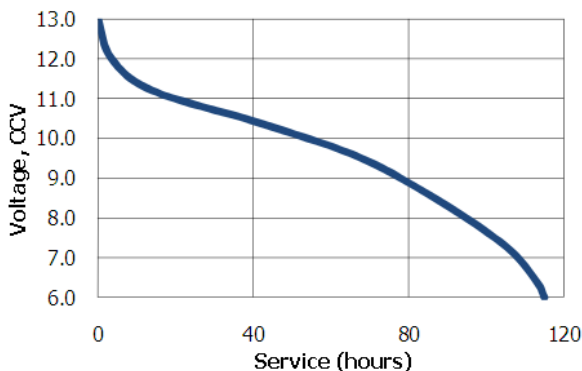

Temperature Characteristics

Schedule: Continuous
Typical Load: 20 KΩ

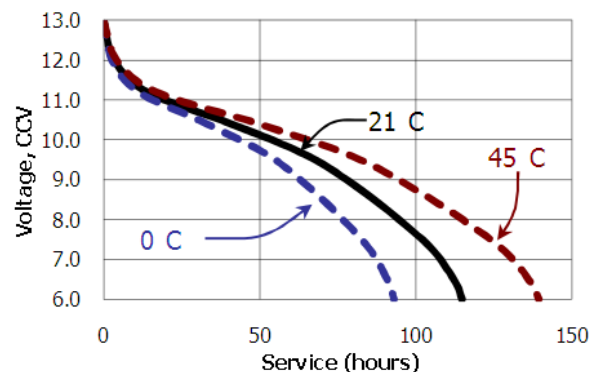

Important Notice

This datasheet contains typical information specific to products manufactured at the time of its publication.
©Energizer Holdings, Inc. - Contents herein do not constitute a warranty.